



RADICAL SR8 **OWNERS MANUAL**



**24 Ivatt Way Business Park
Westwood
Peterborough
PE3 7PG
United Kingdom**

CONTENTS

Introduction.....	5
1. Introduction To Your Car.....	6
1.1 Cockpit Layout.....	6
1.2 Dashboard Layout.....	6
1.3 Alarms.....	6
1.4 Dash Configuration.....	7
1.5 Engine Bay Layout.....	7
1.6 Front Suspension Layout.....	8
1.7 Rear Suspension Layout.....	8
1.8 Electrical Hardware Location.....	9
2. Running Your Car.....	10
2.1 Pre-Session Checks.....	10
2.2 Driver Controls.....	11
3. New Car Shakedown.....	13
3.1 Shakedown Guide.....	13
3.2 Bedding In The Brakes.....	15
4. Tyre Management.....	16
5. Workshop Information.....	17
5.1 Lifting Your Car.....	17
6. Car Setup.....	19
6.1 How To Set Up The Car.....	19
6.2 Corner Weights.....	19
6.3 SR8 Dunlop Setup Sheet.....	20
6.4 Hankook Setup Sheet.....	21
6.5 Drop Heights (In-Depth).....	22
6.6 Hankook Drop Heights.....	23
6.7 Dampers.....	24
6.8 Wet Weather Set-up.....	25
7. Car Servicing.....	26
7.1 Filter Servicing.....	26
7.2 Gearshift Actuator Setup.....	26
7.3 Wheel Speed Sensor Setup.....	27
7.4 Balancing The Throttle Bodies.....	27
7.5 Gearbox Inspection.....	28
7.6 Selector Cover Fitment.....	28
8. Troubleshooting.....	29
8.1 Non starting.....	29
8.2 Charging Issues.....	30
8.3 Gearshift Issues.....	31
8.4 Relays.....	31
9. Torque Figures And Diagrams.....	32
9.1 Engine And Gearbox.....	32
9.2 Suspension Components.....	33
9.3 Braking System.....	34

9.10 Torque Guide.....	35
9.4 Engine Control Parameters.....	37
9.5 Common Parts.....	37
9.6 Fluids	38
9.7 Roll Bar Sizes	39
9.8 Gear Ratios.....	39
9.9 Standard (Long) Gear Ratio Chart	40
9.10 Exploded Diagram (Gearbox)	41
9.11 Component Lifting.....	42
9.12 service schedule	42
9.13 Gearbox Inspection Procedure	43
9.14 Removal and Disassembly.....	43
9.15 Assembly and Refitting	45
9.16 Dunlop Setup Sheet.....	47
9.17 Hankook Setup Sheet	48
10. Version History	49



Dear Radical Owner,

Thank you for purchasing your Radical SR8 and 'welcome' to the worldwide Radical family.

Since its launch in 2006 we have continually developed, refined and improved the SR8 into a performance defining thoroughbred. Now in its 3rd generation, the SR8 is more capable than ever powered by Radical's own latest generation V8.

If properly maintained your SR8 will give you an amazing driving experience, every time you head down the pit lane. Although your car has been built and thoroughly inspected at the Peterborough factory prior to you reading this, please take the time to read through this manual to expand your knowledge of the car. This manual aims to guide you through every aspect of running and maintaining your car.

You will find any further help and support via our website www.radicalsportscars.com or alternatively please contact your local dealer. Parts and consumables can be purchased through our online store, whilst any race series information, sales or technical advice you may need is just an email away.

1. INTRODUCTION TO YOUR CAR

1.1 COCKPIT LAYOUT

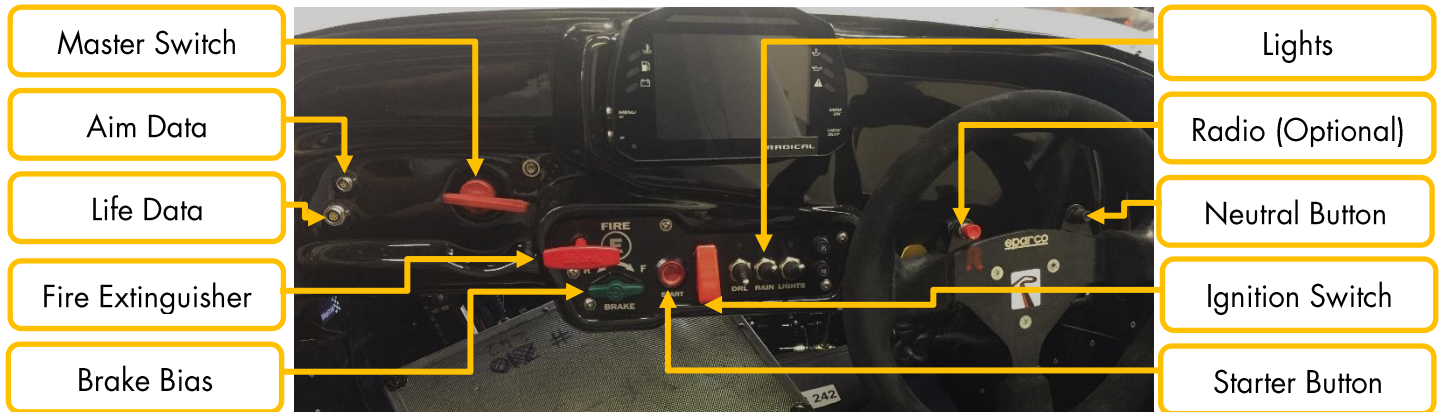

1.2 DASHBOARD LAYOUT

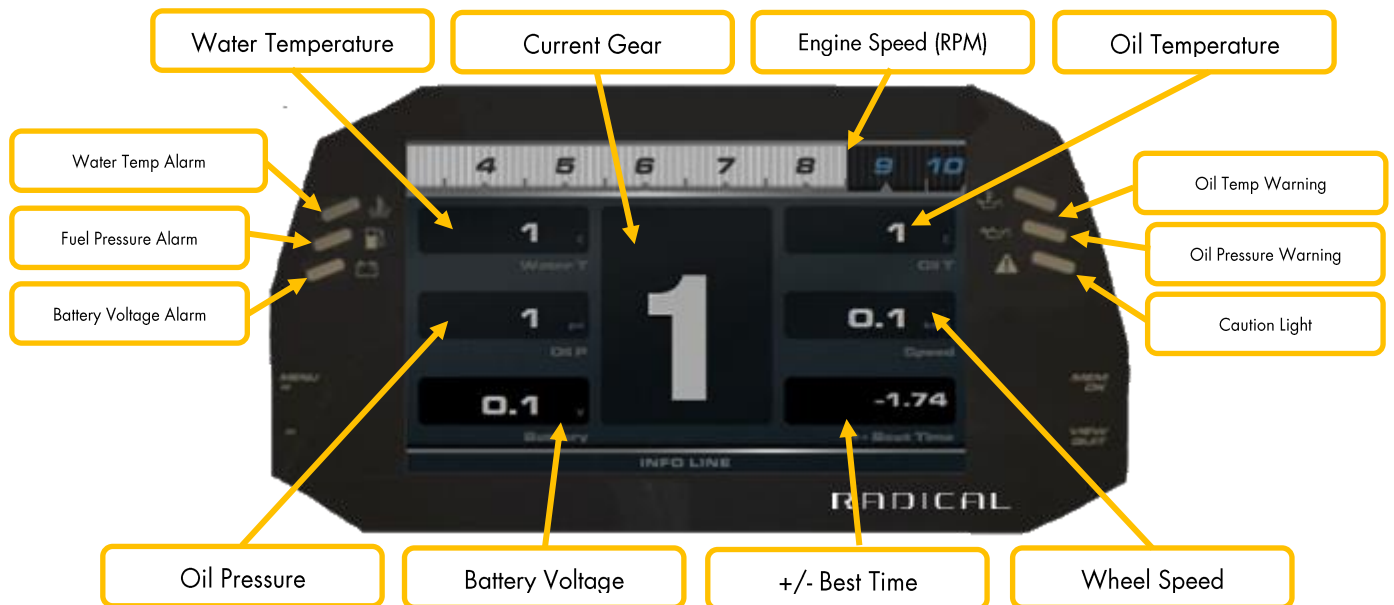

1.3 ALARMS

Dash Alarms		
Alarm	Condition	Warning Lights
High Water Trip	engineEnable=ECT Trip	High Water Temp Alarm Flashing Red + Warning Light Cont. Red
Engine Cold	EOT<45 & RPM>4000	High Water Temp Alarm Cont. Cyan + Warning Light Cont. Yellow
Fuel Press Trip	engineEnable=FP Trip	Low Fuel Alarm Flashing Red + Warning Light Cont. Red
Oil Pressure Trip	engineEnable=EOP Trip	Warning Light Flashing Yellow Low Oil Pressure Cont. Red
Shift Light	RPM= 10300	All Lights Flashing Cyan
Low Oil Pressure	EOP<25 & RPM>2000	Warning Light Cont. Yellow
High Water Temp	ECTOUT>95	High Water Temp Alarm Flashing Red
High Oil Temp	EOT>115	High Oil Temp Alarm Cont. Red
Low Fuel Pressure	FP1<2.5 & RPM>50	Low Fuel Alarm Cont. Yellow
Low Oil Temp	EOT<50	High Oil Temp Alarm Cont. Blue
Low Water Temp	ECTOUT<60	Water Temp Alarm Cont. Blue
Low Battery V	VBAT<11.6	Battery Alarm Cont. Cyan

1.4 DASH CONFIGURATION

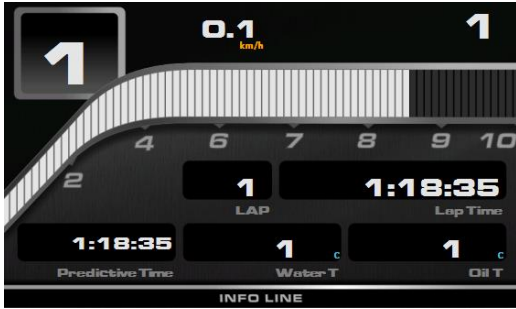

Page 1 – General Running Page



Page 2 – Alternative Running Page



Page 3 – Warm-up/Check Page



Page 4 – Brake Bias Page

1.5 ENGINE BAY LAYOUT

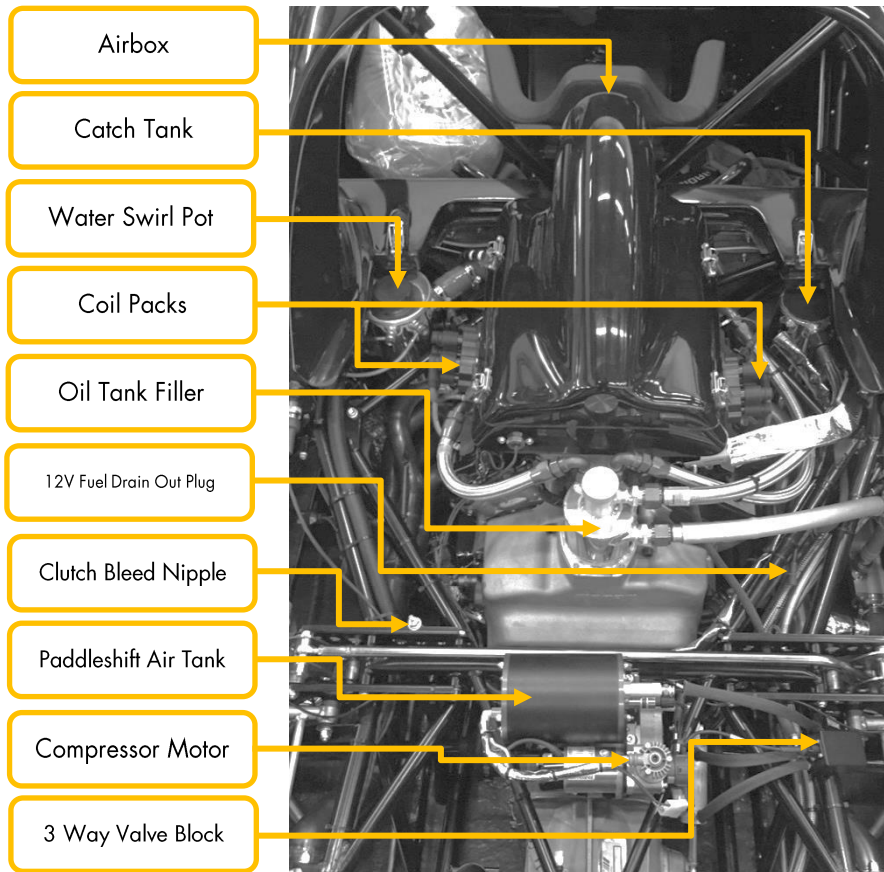

1.6 FRONT SUSPENSION LAYOUT

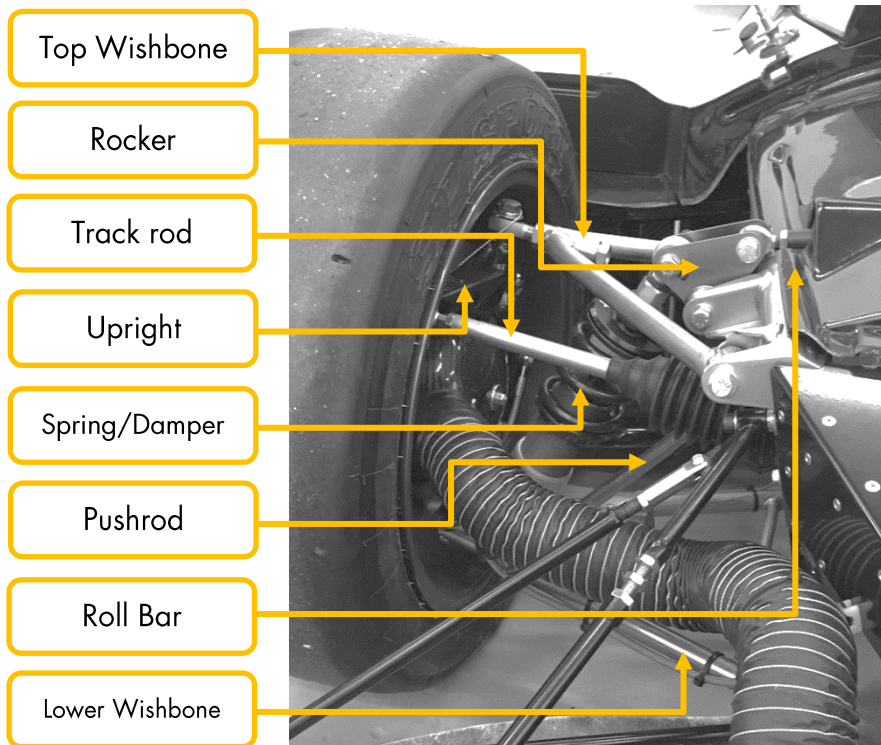

1.7 REAR SUSPENSION LAYOUT

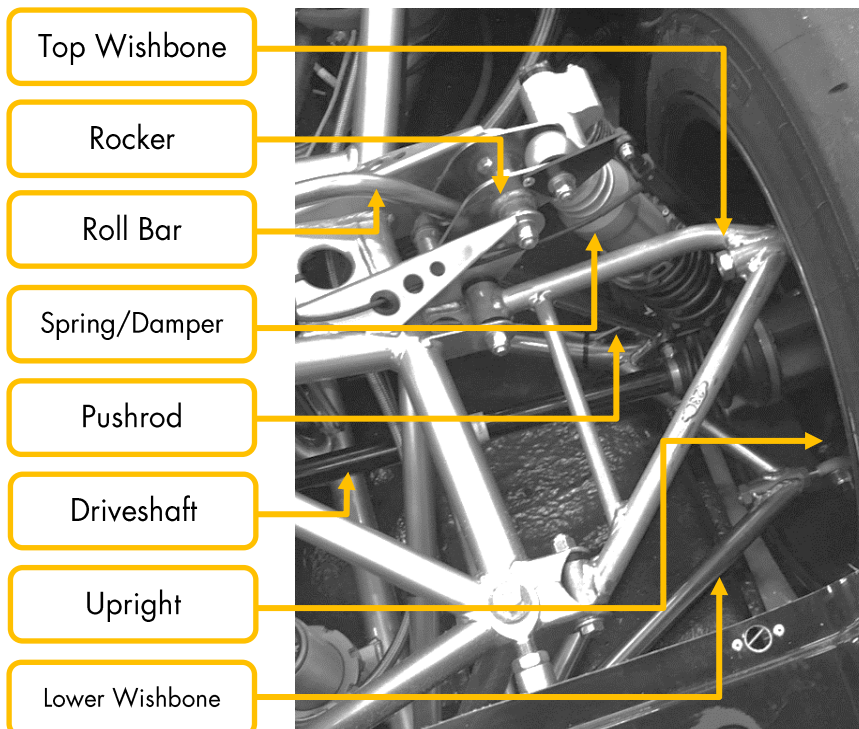

1.8 ELECTRICAL HARDWARE LOCATION

On the right-hand side of the SR8 cockpit you will find an access panel, behind this are the following items:

- ECU
- Barometric pressure sensor
- Electrical relays (Fuel pump, water pump, coolant radiator fan (optional))

To remove the ECU, undo the 4 bolts holding the plate on, then the two bolts in the bracket for the ECU. Then pull the silver clip upwards to an upright position. The connecting hairbrush can then be rotated off the ECU. To refit repeat these steps in reverse. This should not be removed unless there is an issue or the engine is being returned for rebuild.

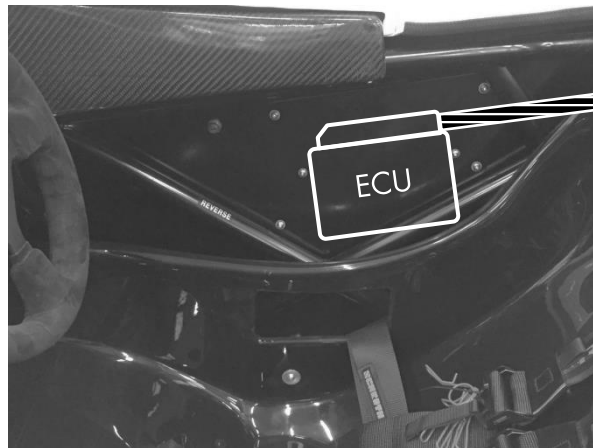

2. RUNNING YOUR CAR

Upon delivery of your new car it is recommended you check the following items:

- If the car has been shipped, be sure to check the tracking of the front and rear wheels, it is possible that the securing straps may have been overtightened and pulled the car out of alignment.
- Make sure the master switch wasn't left on during transit and the battery hasn't run flat.
- Check that the driver is comfortable in the car. The seat can be adjusted forwards and backward by loosening off the 3 bolts either side of the seat. The pedals stops can also be adjusted. If the pedal adjustment is not enough a short pedal box is available, please contact your local dealer for more information.
- Remove the fire extinguisher safety pin prior to starting the car.
- Check all fluid levels; coolant, brake, clutch and engine oil. Fluid specifications can be found later on in this manual.
- Ensure there is a sufficient amount of fuel in the car. We strongly advise a minimum of 98 Octane. For further information on fuel please contact engines@radicalsportscars.com

To ensure the reliability of your car and engine we would strongly recommend following this procedure every time you start running your SR8:

Dry cranking - Before starting the car ensure the oiling system is well lubricated, 'dry crank' the engine by pressing the starter button for a few seconds before turning the ignition on, ensure it is in neutral. Keep an eye on the dash to check for oil pressure being displayed.

Warming up the car - Check the water level then start the engine and allow it to idle until the water gets above 80°C and the oil has started to warm up. The oil will take longer to heat up than the water meaning you will need to switch the engine off when water reaches 80°C and allow the engine to rest for a short time whilst the water cools down before running up the engine again to get the oil up to temperature. Optionally you can use an engine oil pre heater to warm the oil prior to starting the engine, for more information please contact your local dealer.

Oil Check - When the oil temperature is over 50°C raise the RPM to 4,000 for 5 seconds to fully scavenge the oil, then switch the engine off. Using the dipstick, check the oil level; the oil level should be in between the minimum and maximum marks of the dipstick. If the car requires oil, it is recommended to follow the same process of holding the RPM at 4,000 for 5 seconds, to re check the oil level.

2.1 PRE-SESSION CHECKS

Despite all the thorough checks which are carried out on all our cars before they leave the factory, it is important you also do some basic checks before you take the car to the track for the first time.

- Torque the centre lock wheel nuts to 260lb/ft. Fit the safety retaining clips.
- Use the tyre guide to get a rough idea on cold starting tyre pressures and ensure these are set correctly.
- Double check the fire extinguisher system is set to active (electrical specification) and the pin is out of the lever.
- Ensure the mirrors are all in the correct position for the driver
- Dependent on weather conditions, you may need to blank off the side-pod intakes in order to maintain recommended engine running temperatures on track. Running outside these temperature ranges can be harmful to the performance of your engine.
- The gearbox must be warmed up, with the car on stands and the rear wheels off.

Target engine running temperatures:

Parameter	Temperature (C°)
Oil Temperature (EOT)	90° – 110°
Water Temperature (ECT)	70°– 90°

2.2 DRIVER CONTROLS

STARTING THE CAR

To start the car, turn on the master switch and wait for the dash to load. Switch the ignition on. You can now press the starter to turn over the starter motor.

IMPORTANT NOTE

As with any race car, it is important to put the car in neutral and release the clutch when stationary. This will significantly reduce clutch bearing wear. Ensure the car is always started in neutral (Note, the clutch switch is no longer required, as it is on a pressure sensor in the clutch line).

PADDLESHIFT CONTROLS

- To pull away, depress the Clutch, hold the neutral button in on the steering wheel and pull the up paddle to get to first. Once you have pulled away in first gear you can then shift up as normal all the way to 6th.
- The SR8 is fitted with an automatic blipper and ignition cut controls. This allows you to flatshift up the gearbox and means you **do not** have to blip the throttle on the way down the gearbox.
- The paddleshift system has safety controls that can override paddle requests help to reduce damage to the engine caused by overrevs. Because of this the system may deny shift requests if the rpm is too high for a downshift or you are still applying throttle whilst trying to downshift. These safety overrides are explained in more detail in the Radical Data Manual.
- When stopping the car and wanting to select neutral remember it is between first and reverse gear. To select neutral when the car is traveling at low speeds or has stopped; hold the neutral button and shift down from first.

The gear order is shown below:

R → N → 1 → 2 → 3 → 4 → 5 → 6

STOPPING THE CAR

Use the ignition switch to turn off the car. Do not turn the car off via the master switch, unless in an emergency. Keeping the master switch turned on after the engine has stopped running allows the cooling fan and pump to continue to run if required to prevent heat soak. After 120 seconds they will automatically turn off and the master can be switched off.

BRAKE BIAS

The brake bias can be adjusted to suit the drivers needs dependant on the circuit, driving style and weather conditions. As a starting point, we recommend starting at 57%, which is 7% biased towards the front. During wet conditions it is advisable to move the bias rearwards at around 5%.

3. NEW CAR SHAKEDOWN

At Radical, we pride ourselves on our quality control and rigorous testing procedures that we have in place for every new car. All new cars are subject to a 100 point post production inspection and track simulation on our rolling road dynamometer prior to delivery. However, it is not possible to replicate the forces exerted driving round a race track. The first time you drive your new SR8 round a track is the first time the car has experienced the G-force you feel through the seat of the car. For this reason, we recommend our 'shakedown' procedure is followed for all new cars.

3.1 SHAKEDOWN GUIDE

Warm the car up and complete the pre-session checks. The first track session for a new car is also the first time the brakes have been used under load. All cast iron brake discs for competition use need to be bedded-in to ensure heat stabilisation and improve resistance to cracking. Cracks or warping can occur during the first few heavy stops if careful bedding is not carried out.

Your car comes fitted with carbon metallic brake pads. To bed in the brakes and achieve maximum stopping power, a film of carbon must be transferred to the discs. Additional notes on brake bedding can be found in the following section.

To help with brake bedding initially blank the brake cooling ducts off up to $\frac{3}{4}$ to increase temperature build up, depending on ambient temperature.

RUN 1 (OUT & IN)

Driver:

- For the driver this is a good way for you to start to learn about the car. It is important to try and run through every gear if possible; it is advised to change gear at 5,000 rpm. During this run only use light pressure on the brake pedal. (See 'Bedding in Brakes' below)

Technician:

- Remove the engine cover and check for leaks and for any components rubbing

RUN 2 (3 LAP RUN)

Driver:

- Now the engine bay has been checked, it's time to start building up the temperature and speed. Be mindful that the brakes and tyres are still new, and won't have reached their peak performance yet. Start to build up brake pressure, and roll some more speed in to the corners. Bring the RPM up to 8,000 before shifting up through the gears.

Technician:

- Check the tyre pressures
- Check the running temperatures of the oil and water and adjust any coverings in order to ensure the car runs at target temperatures
- Again, remove the engine cover and inspect the engine bay for leaks
- Re check the wheel torque (260ft/lb)
- Allow the brakes to cool for a few minutes before heading back out on track.

RUN 3 (5 LAP RUN)

Driver:

- During this run build up to full brake pressure, and use the full rev range before shifting (10,000rpm).

Technician:

- Check the brake discs, they should now have started to 'blue' near the bell showing they have heated up sufficiently. Allow the brakes to cool once again and remove the blanking on the ducts for the next session
- Check the tyre pressures
- Check for play in the wheel bearings
- Recheck wheel nut torque for a final time (260ft/lb)

RUN 4 (NORMAL SESSION)

The car can now be run as normal. After this session is complete it is recommended to spanner check the whole car, again pay final attention for potential leaks and a give the car a good general inspection. When spanner checking the car, ensure suspension components are not overtightened as this will restrict the movement of these components.

3.2 BEDDING IN THE BRAKES

This procedure should be followed each time new discs are fitted to your car:

- The brake ducts should be $\frac{3}{4}$ blanked off in order to allow the brakes to warm up through the bedding in period, previously bedded pads should be used if possible.
- 3 lap run - use the brake lightly (<20bar application) on the in lap and allow brakes to cool for 5 mins (stay off brake pedal in pits when stationary!)
- Next run 5 laps – increase brake pressure to build up temperature in the discs if the conditions permit (above 40 bar pressure). The braking potential of the car will start to fade and any potential vibration will surpass; this is a sign that the bedding procedure is complete.
- It is possible to pick up a vibration or ‘judder’ through the brake pedal. This is due to the disk bell and disk becoming aligned for the first time; this is not a process that can be simulated in the build of the car. It is therefore very important that if the driver feels they have brake judder they continue to build up brake pressure and heat in the disk. And not to stop or decrease pedal pressure, to do so has the potential to make the vibration worse.
- Complete a cooling down lap with moderate brake pressure before stopping the car. Allow the brakes to cool for 15 minutes. Do not apply brakes whilst stationary during the cooling down period.
- We strongly advise AP Racing thermal paint is used; if so then only the green paint (430°C) should have fully turned to white and the orange will have slightly turned (560°C) on the outside edges of the discs during the bedding procedure. If fitted, brake pressure sensors can be used to monitor the bedding in procedure.

IMPORTANT NOTES

With cast iron discs, brake pressures should not exceed 20bar during the out lap, even with pre-bedded discs. This is to prevent heat shocking which causes the discs to crack, this occurs when the disc is taken from ambient temperature up to 600°C very rapidly such as heavy braking on the out lap. When stationary never hold pressure on the brake pedal, this can cause warping and/or the discs and pads to bind.

4. TYRE MANAGEMENT

The table below shows the suggested running pressures and pressures for race tyres:

Dunlop Cold Starting Pressure			
Slicks		Wets	
22	22	23	23
21	21	22	22

Hankook Cold Starting Pressure			
Slicks		Wets	
20	20	22	22
19	19	22	22

Dunlop Hot Pressure			
Slicks		Wets	
28	28	28	28
28	28	28	28

Hankook Hot Pressure			
Slicks		Wets	
28	28	28	28
28	28	28	28

- Please note that the starting pressures are to only be used as a guide; conditions on the day will alter where you should start your pressures. Hot conditions will increase the pressure rise over the same period of time
- Fit valve caps when running
- Temperature spreads must not exceed 15°C across the front and 10°C on the rear
- Measure tyre temperature spreads, 3cm in from each edge of the tyres and in the centre, make sure you are not measuring the temperature of any pickup on the tyre
- Avoid kerbs on the out-lap when the tyres are cold
- It is important to take advice from your tyre manufacturer to ensure you are following their recommended setup parameters.

TYRE PERFORMANCE ANALYSIS

- Decisions based on handling should always be preceded with thorough examination of tyre working surface.
- Use the temperatures, pressures, data and driver feedback with the visuals of the tyre to get the best all round view of car and tyre behaviour.
- Measure the tyre temperatures and pressures as often as possible straight after a fast lap, get the driver to do a full pace in-lap, in order to get the best readings.

TYRE CONDITION FEEDBACK

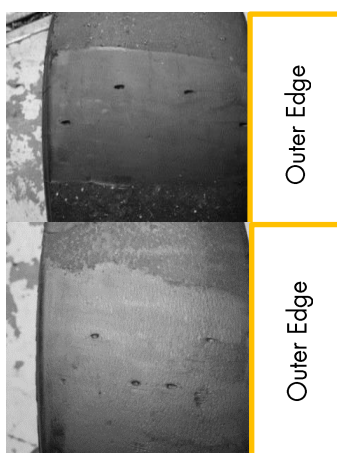

When examining a tyre, always check both sides. The unloaded side can drag the inner wheel, causing excessive negative camber and overheating in the inner edge.

When measuring the temperature spreads start from the inner edge then work to the outer edge.

The picture on the left is an example of a rear tyre in good condition.

This is an example of a well-worn front tyre, judging by the wear indicators and the level of graining it suggests the car has been suffering with understeer. This could also be run with more camber.

If a tyre is graining on either side, this can be used to judge whether the right level of camber is being used

5. WORKSHOP INFORMATION

After every day the car has run the car should be inspected thoroughly in a workshop environment.

5.1 LIFTING YOUR CAR

AIR JACKS

In order to raise the car, insert the 'air jack lance' into the fitting as shown in the picture below. Slowly build up the pressure in the regulator, until the car is fully off the ground. (300-350psi)



Before working on the car, the air jack safety clamps must be inserted, to do this simply push the open side of the yellow clamp around each of the three air jacks as shown.

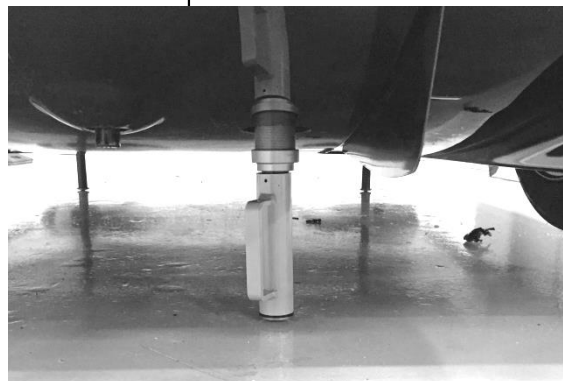

To release the air jacks, pull back on the fitting shown in the picture. Slowly pull the fitting to gradually release the pressure in the system, pulling it quickly will result in the car dropping to the ground rapidly. The air system will bleed out and the car will slowly lower onto the ground if it is released correctly. You must leave the fitting on the open position when it is empty so that the system cannot re-pressurise.



JACKING POINTS

The front jacking point is in the centre of the front diffuser, just under the front chassis rail. As shown in the picture.

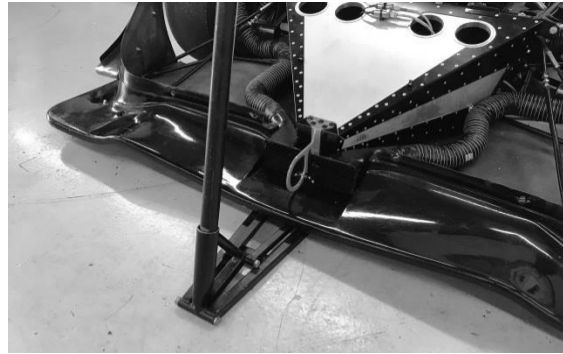

The rear jacking point is under the rear diffuser in the centre of the car, a welded bar protrudes the diffuser around the mid-point.

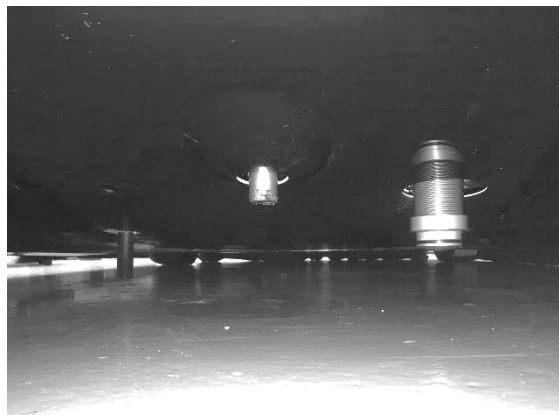

LIFTING POINTS

To lift the car onto a high stand we recommend lifting the car with a crane, rated to at least the weight of the car. To lift the car, mount a strap around the very top of the forward-facing stays, as shown. Be careful not to damage the bodywork.



6. CAR SETUP

When the car leaves the factory, it will have a base setup on the car which is shown on the next page. This is a setup which has shown to work over the years it has been adapted to suit various drivers' needs as they feel more comfortable with the car.

6.1 HOW TO SET UP THE CAR

Setting up the Radical may seem a daunting task at first; however, adjustments are incredibly simple with everything being of easy access allowing for fast setup changes whenever you feel the need to adjust certain areas. Below is a step by step guide of how to work with the car on the flat patch.

1. Check front pushrod lengths are equal & front springs have the correct turns of pre-load. The front pushrod is jigged from production at 230mm.
2. Check rear spring platform-to-cap distance is equal (approx. 125mm)
3. Ballast with 80Kg (10Kg in footwell by the pedals, 70Kg in seat) unless specific driver weight is known.
4. Lock steering to straight ahead using dummy steering wheel
5. Set tyre pressure to hot pressure from setup sheet
6. Disconnect front & rear anti-roll bars
7. Check dampers are set to minimum all round
8. Bounce & roll car to settle suspension
9. Check drop heights and adjust average of front & rear to be within 1mm of target
10. Set cambers (+/- 0.1° from target)
11. Set toes (+/- 0.5mm from target)
12. Roll car off platform, turn on scales and zero
13. Roll car back onto platform, repeat bounce & roll
14. Check corner weights. Target is within 5Kg across front, and within 2% for diagonals
15. Adjust to correct using rear platforms only
16. Re-adjust drop heights equally on front pushrods and rear spring platforms to achieve target. (The drop height will probably not be equal, due to the offset seating position, so target drop height should be an average of the left & right readings.)
17. Re-connect anti-roll bars making sure there is no pre-load
18. Set dampers, they should always be set from fully closed.
19. Turn off scales
20. Ensure the diffuser is level front to back and side to side.

6.2 CORNER WEIGHTS

One of the most important setup factors is to ensure that the front corner weights are as equal as possible. The cross weight is not as crucial in comparison. (The offset driving position of the driver will usually mean that the weight cannot be made exactly equal)

To adjust the front corner weights, raise or lower the diagonal rear.

The maximum difference in front weights should be no more than 5kg (11lb)

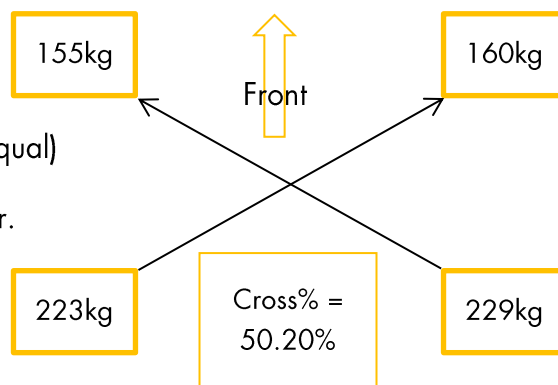

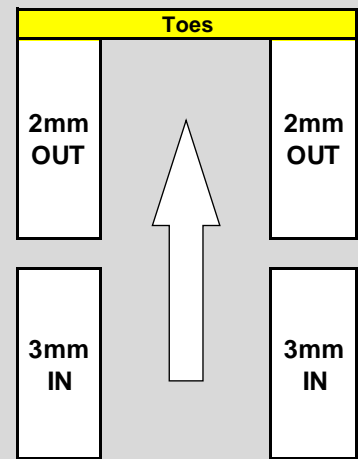
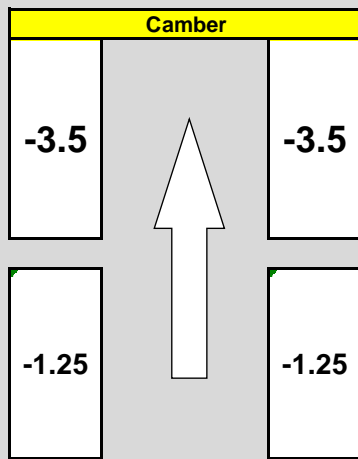

Triple Intrax		Springs/Preload		Triple Intrax	
Bump LS:	-12	95Nm 100mm Preload 3 Turns	FARB	Bump LS:	-12
Bump HS:	-25		Soft 15.8mm	Bump HS:	-25
Rebound:	-25		Medium 19mm	Rebound:	-25
			Hard 22.2mm X Hard 22.2mm black		

Corner weights(Est) / Drop Height		
75m m	Front diffuser H	75mm
	40mm	
168m m	Ballast Weight	168mm
	80kg	
Weight Estimate	Cross% 50.3	Weight Estimate
153	Total weight kg 715 +80kg BW*	160
	Rake mm	

Triple Intrax		Springs/Preload		Triple Intrax	
Bump LS:	-10	110Nm 100mm Preload 0 Turns	RARB	Bump LS:	-10
Bump HS:	-25		Soft 12.7mm	Bump HS:	-25
Rebound:	-25		Medium 15.8mm	Rebound:	-25
			Hard 19mm X Hard 22.1mm Super hard 22.1 black		

70m m	15mm		70mm
220m m	↑		220mm
Weight Estimate	LHD	RHD	Weight Estimate
222		✓	228

Dive planes:		Tyre Pressures PSI (Cold & Hot)	
		24	24
		Dunlop Tyre Compound	
		720	

PADS
01

SR8 Gearing	
Short	
Medium	Std
Long	
X long	

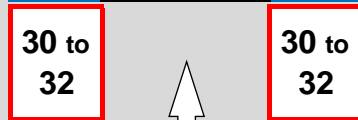

SR3 Gearing	
3.409	n/a
3.235	n/a
3.071	n/a
2.917	n/a

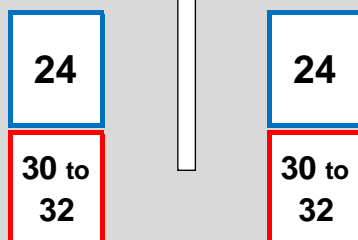
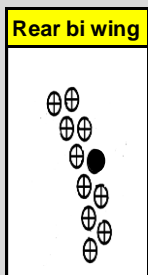

PADS
01

Chain Drive Gearing	
FRONT	REAR
n/a	n/a

Note: When carrying out set-up on flat-patch, set tyre pressures to hot pressure. Ensure that they are returned to cold pressures after setup is complete.

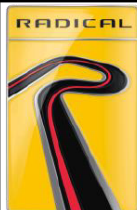

SR8 - Factory setup sheet - Hankook

Note: When carrying out set-up on flat-patch, set tyre pressures to hot pressure. Ensure that they are returned to cold pressures after setup is complete.

Date		Chassis #		Job #	
		Technician	1	Technician	

Camber		
-3.2		-3.2
-1.4		-1.4

Toes		
2mm out		2mm out
3mm IN		3mm IN

Triple Intrax		Springs/Preload				Triple Intrax	
Bump LS:	-10	Rate	FARB	Rate	Bump LS:	-10	
Bump HS:	-30	130	Soft 15.8mm	130	Bump HS:	-30	
Rebound:	-5		Medium 19mm		Rebound:	-5	
		Length	Hard 22.2mm	Length			
		100	X Hard 22.2mm	100			
		Preload		Preload			
		4 turns		4 turns			

Ride	Front Diffuser H	Ride
78mm	40mm	78mm
	Ballast Weight	
	80kg	
Drop	Cross%	Drop
162mm		162mm
Weight	Total weight	Weight
kg	kg	kg

Triple Intrax		Springs/Preload				Triple Intrax	
Bump LS:	-4	Rate	RARB	Rate	Bump LS:	-4	
Bump HS:	-20	110	Soft 12.7mm	110	Bump HS:	-20	
Rebound:	-30		Medium 15.8mm		Rebound:	-30	
		Length	Hard 19 mm	Length			
		100	X Hard 22.2mm	100			
		Preload	XX Hard 22.2mm	Preload			
		0		0			

Ride	Rake mm		Ride
79mm	21mm		79mm
Drop			Drop
209mm			209mm
Weight	LHD	RHD	Weight
kg			kg

Fuel Level

Upper Dive planes: Y / N
Lower Dive planes: Y / N

Tyre Pressure (PSI) (Cold & Hot)			
28	Hankook	28	PADS
20		20	01
28		28	PADS
19		19	01

Rear Wing	
Holes (from the bottom)	
Main	3 out of 4
Bi-wing	7 out of 9

Comments:

6.5 DROP HEIGHTS (IN-DEPTH)

The drop heights are measured with a 4" bar, the bar is inverted for the front, as shown in the picture. Chassis rake will be the difference between 'Calculated Ride Height' and 'Rear Ride Height'.

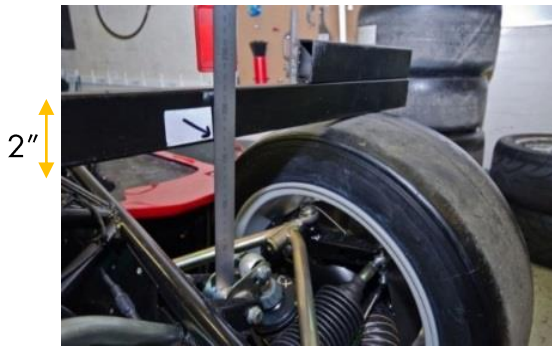

FRONT		
Measuring to Rocker Pivot		
Front Drop Height	Chassis Height	Calculated Ride height under lowest point on chassis
153mm	90mm	70mm
154mm	89mm	69mm
155mm	88mm	68mm
156mm	87mm	67mm
157mm	86mm	66mm
158mm	85mm	65mm
159mm	84mm	64mm
160mm	83mm	63mm
161mm	82mm	62mm
162mm	81mm	61mm
163mm	80mm	60mm
164mm	79mm	59mm
165mm	78mm	58mm
166mm	77mm	57mm
167mm	76mm	56mm
168mm	75mm	55mm
169mm	74mm	54mm
170mm	73mm	53mm
171mm	72mm	52mm
172mm	71mm	51mm
173mm	70mm	50mm
174mm	69mm	49mm
175mm	68mm	48mm
176mm	67mm	47mm
177mm	66mm	46mm
178mm	65mm	45mm
179mm	64mm	44mm
180mm	63mm	43mm
181mm	62mm	42mm
182mm	61mm	41mm
183mm	60mm	40mm
184mm	59mm	39mm
185mm	58mm	38mm
186mm	57mm	37mm

REAR	
To Front Bush on Rear Top Wishbone Bolt	
Rear Drop Height	Chassis Height
210mm	80mm
211mm	79mm
212mm	78mm
213mm	77mm
214mm	76mm
215mm	75mm
216mm	74mm
217mm	73mm
218mm	72mm
219mm	71mm
220mm	70mm
221mm	69mm
222mm	68mm
223mm	67mm
224mm	66mm
225mm	65mm
226mm	64mm
227mm	63mm
228mm	62mm
229mm	61mm
230mm	60mm
231mm	59mm
232mm	58mm
233mm	57mm
234mm	56mm
235mm	55mm
236mm	54mm
237mm	53mm
238mm	52mm
239mm	51mm
240mm	50mm
241mm	49mm
242mm	48mm
243mm	47mm

6.6 HANKOOK DROP HEIGHTS

The drop heights are measured with a 4" bar, the bar is inverted for the front, as shown in the picture. Chassis rake will be the difference between 'Calculated Ride Height' and 'Rear Ride Height'.

FRONT		
Measuring to Rocker Pivot		
Front Drop Height (mm)	Chassis Height (mm)	Calculated Ride height under lowest point on chassis (mm)
153	87	67
154	86	66
155	85	65
156	84	64
157	83	63
158	82	62
159	81	61
160	80	60
161	79	59
162	78	58
163	77	57
164	76	56
165	75	55
166	74	54
167	73	53
168	72	52
169	71	51
170	70	50
171	69	49
172	68	48
173	67	47
174	66	46
175	65	45
176	64	44
177	63	43
178	62	42
179	61	41
180	60	40
181	59	39
182	58	38
183	57	37
184	56	36
185	55	35
186	54	34

REAR	
To Front Bush on Rear Top Wishbone Bolt	
Rear Drop Height (mm)	Chassis Height (mm)
210	78
211	77
212	76
213	75
214	74
215	73
216	72
217	71
218	70
219	69
220	68
221	67
222	66
223	65
224	64
225	63
226	62
227	61
228	60
229	59
230	58
231	57
232	56
233	55
234	54
235	53
236	52
237	51
238	50
239	49
240	48
241	47
242	46
243	45

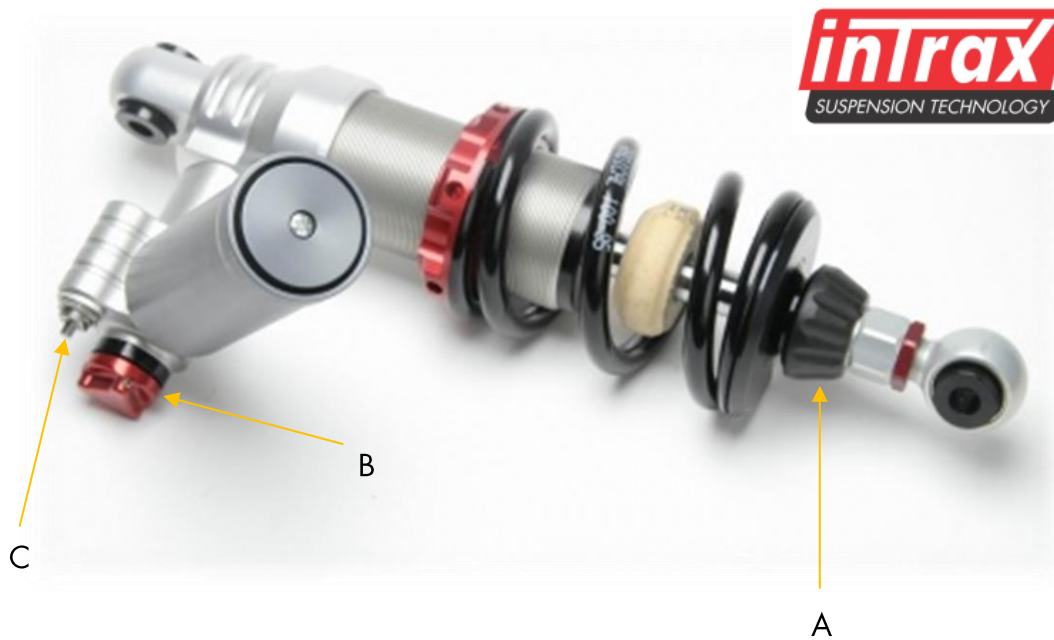
**A – Rebound:**

The rebound controls the speed of the damper's extension. The more rebound resistance you add, the slower the damper will return out. This can be used on the front to fix mid-corner understeer, and on the rear to aid traction. This adjuster has approximately 50 clicks from fully closed.

B – High speed bump compression:

High speed bump compression (refers to the speed of the piston rod into the damper) controls the high frequency compressions of the damper. In simple terms it controls how the car reacts to small bumps and kerbs. This adjuster has approximately 50 clicks from fully closed.

C – Low speed bump compression:

Low speed bump compression controls how slow or fast the damper reacts under compression. Increasing the low speed bump will have a similar (though smaller) effect to increasing the spring rate. This adjuster has 15 clicks from fully closed.

6.8 WET WEATHER SET-UP

When you venture into the wet conditions, the car setup can be altered in order to give the driver the best chance of staying on the circuit. Shown below is a guide to the changes to make to the car in the wet.

Camber		
½° less negative	↑	½° less negative
¼° less negative		¼° less negative

Toe	
Do <u>NOT</u> change	Do <u>NOT</u> change
Do <u>NOT</u> change	Do <u>NOT</u> change

Dampers		Springs / pre-load			Dampers	
Bump LS	5 softer	Front anti-roll bar			Bump LS	5 softer
Bump HS	10 softer	5Nm softer, same P/L	Next softest	5Nm softer, same P/L	Bump HS	10 softer
Rebound	5 softer					Rebound

Corner Weights / Ride Height	
Do <u>NOT</u> change	Do <u>NOT</u> change

Dampers		Rear anti-roll bar			Dampers		
Bump LS	5 softer	10Nm softer	Next softest	10Nm softer	Bump LS	5 softer	
Bump HS	10 softer					Bump HS	10 softer
Rebound	5 softer					Rebound	5 softer

Do <u>NOT</u> change	Do <u>NOT</u> change
----------------------	----------------------

Dive Planes		Tyre Pressure (cold)	
Plus 1		22psi	22psi
Rear Wing	No Change	21psi	21psi
Main	No Change		
Flap	Up 1 hole		

Brake Balance
2 full turns to rear (720°)

7.1 FILTER SERVICING

Engine Oil Change - Radical recommends changing engine oil every 6 hours, to do this remove the large oil pipe from the bottom of the oil tank, located in the right-side of the bell housing. There will be small amounts of oil left in the engine, to drain the last bit of oil, remove the four 10mm M6 bungs on the underside of the engine, it is recommended to fit new crush washers when re-fitted these. Do so with pipe sealer and torque up to 100 in/lbs, re-lockwire.

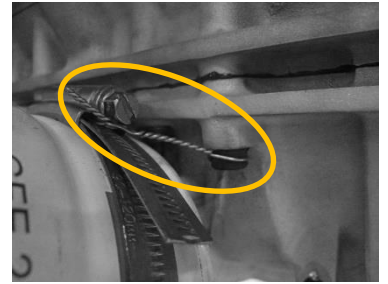

Engine Oil Filter Change - When the oil is changed we recommend changing the oil filter at the same time to comply with our engine warranty conditions. Remove and discard the old filter. A thin film of oil should be applied to the o-ring on the new filter, use the oil filter tool to torque the filter to 20Nm. Fill the engine back up with fresh oil to the correct level. A jubilee clip should be fitted as shown in the picture with Lockwire attaching it to the drilled bolt in the lower case.



Fuel Filter - The fuel filter should be changed every 40 hours, it is located in the fuel regulator housing which is on the left-hand side of the car underneath the engine cover. The unit also houses the pressure sensor and the regulator itself which is in the centre of the unit. The filter is located on the right as shown in the picture, it is secured by a circlip that when removed, the fuel filter can be removed.

Air Filters - The air filters should be inspected and cleaned before each race weekend/test day. When cleaned it should be oiled to the manufacturer's instructions.

Gearbox Oil Change - To remove the gearbox oil, remove the (19mm) oil drain bung on the underside of the back casing and let the oil drain out. When re-filling use 3 litres of Neo synthetics gearbox oil. 3.7 litres must be used if the gearbox and radiator is totally dry.

7.2 GEARSHIFT ACTUATOR SETUP

The actuator is a key part in changing gear in the SR8, if the actuator is incorrectly adjusted it can cause gear shift issues, and has the potential to damage the internals of your gearbox. Use the jig (AT0033) for setting the Actuator length on the SR8, the total length from the casing to the nut should be 51mm. This is simply done as shown in the picture below:



7.3 WHEEL SPEED SENSOR SETUP

Use the jig for setting the wheel speed sensor (AT0042). Using a pair of 13mm spanners, set the wheel speed sensor no closer to the pickup point than the thickness of the Wheel Sensor Gauge (2mm). The pickup point is the end of the brake disc bolts on an SR8. When fitted, check the sensor is working by ensuring it is plugged in, then turn the power on and spin the disc, the sensor should light up when it sees each disc bolt. This is shown in the image below.



7.4 BALANCING THE THROTTLE BODIES

To set up the individual throttle bodies on the RPE V8, please follow these rules:

When the engine is idling at 2000rpm, the Synchrometer reading needs to be equal on each of the individual throttle bodies and the TPS should be 4.0%. The TPS value can be seen on a computer connected to the ECU or on the dashboard, only adjust when the engine is not running.

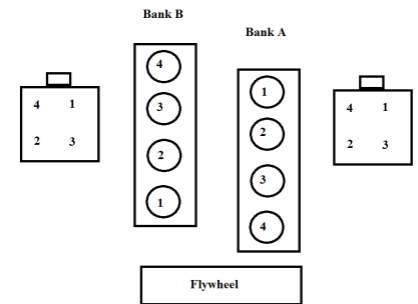

This is achieved by adjusting the idle speed screw, adjustment rods and throttle body adjusters.

Ensure that all eight of the bodies open fully and evenly.

During this procedure it is essential that you have a laptop connected, with PTmon displayed. Check the engine coolant temperature is a minimum of 50°C and maximum of 90°C while the engine is running.

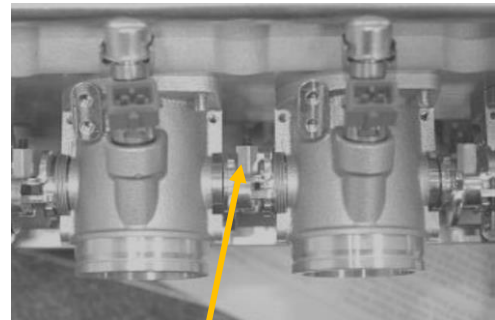
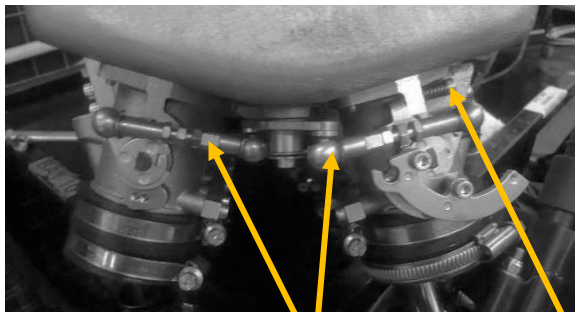

Adjustment Rods Idle Speed Adjustment Screw Individual Throttle Body Adjustment

7.5 GEARBOX INSPECTION

We recommend the gearbox to be inspected every six hours, the teeth should be inspected for excessive wear and pitting. Check the condition of all the dog rings for rounding.

7.6 SELECTOR COVER FITMENT

Some of the newer gearboxes from Quaife, no longer have the mark on the selector cover to ensure correct fitment.

This means it can be out of alignment with the selector barrel if re-fitted incorrectly. Please see the photos below showing the cover selector wheel, in both the correct, and incorrect position. The teeth should be either side of the pin.

Always check the gear voltage position with the life software to also ensure correct fitment.

SR8 Neutral voltage - 1.051v

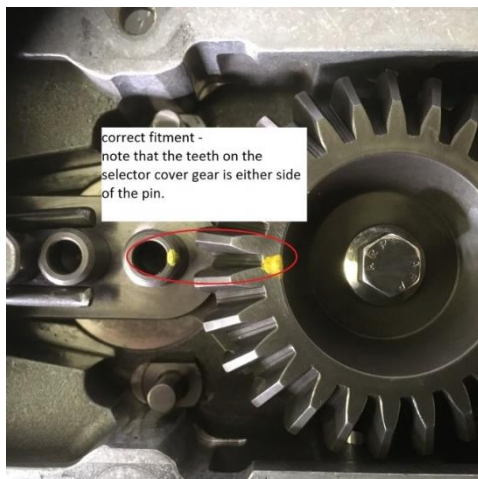

For gearboxes with the mark, it should be positioned as shown in the diagram below. The selector barrel must also be fully rotated downwards if looking at the gearbox from the right-hand side of the car, or fully clockwise if looking from the rear. The cover can then be fitted.

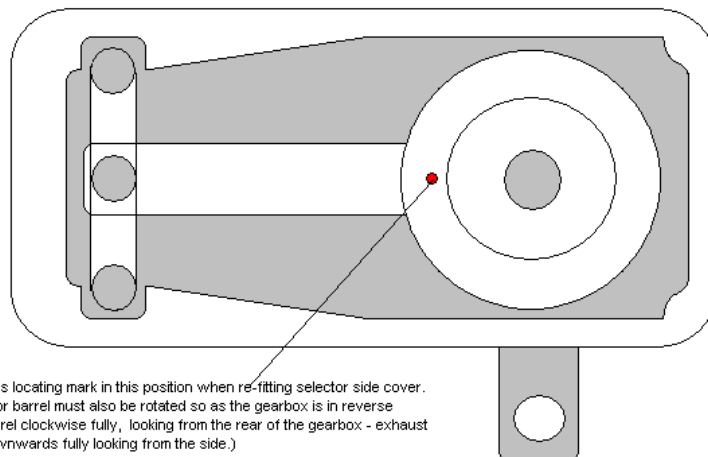

position this locating mark in this position when re-fitting selector side cover. the selector barrel must also be rotated so as the gearbox is in reverse (rotate barrel clockwise fully, looking from the rear of the gearbox - exhaust end or downwards fully looking from the side.)

with ptmon connected, the neutral ingear voltage should read 1.052v

8. TROUBLESHOOTING

8.1 NON STARTING

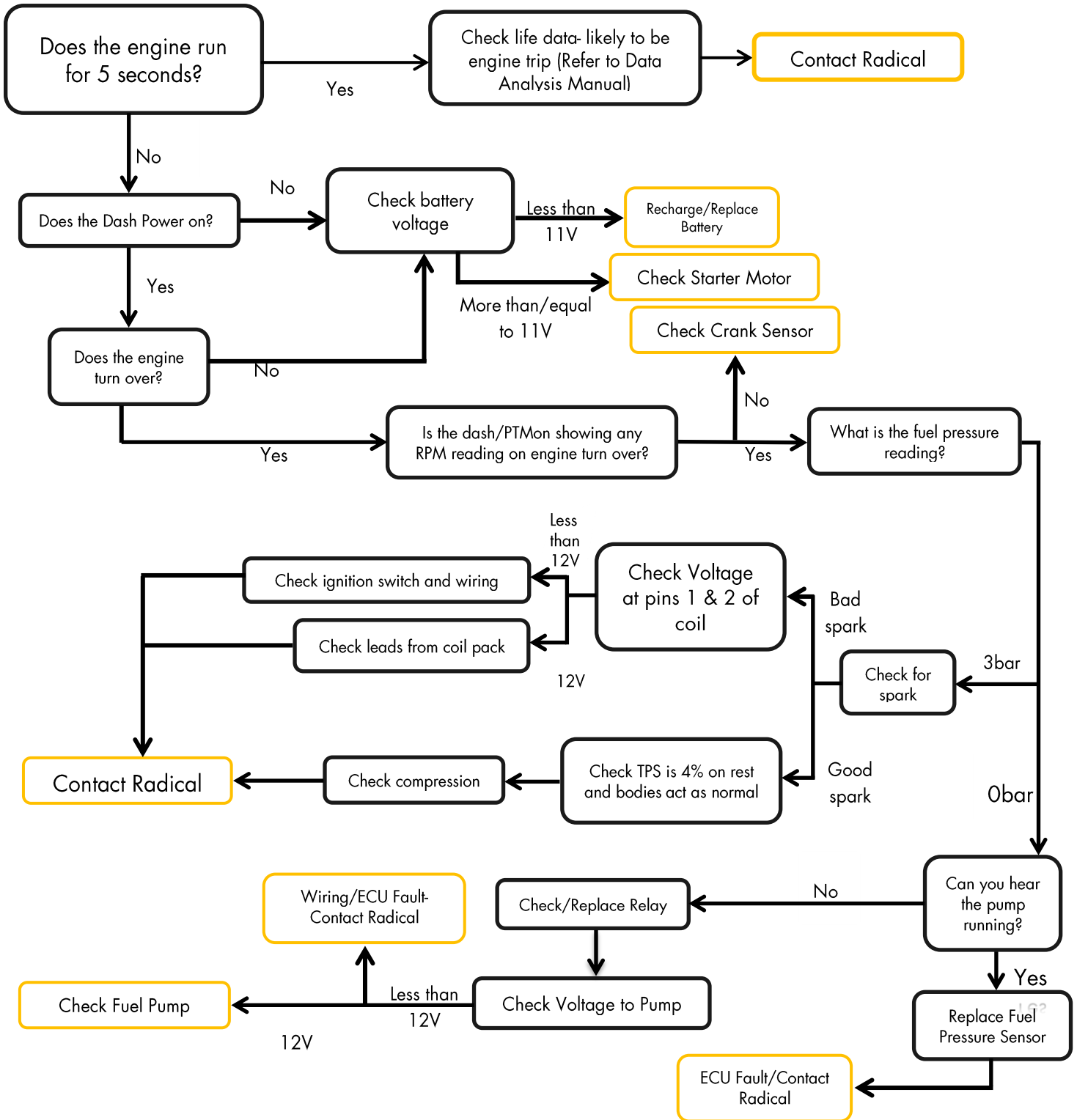

8.2 CHARGING ISSUES

The SR8 should be charging between 13.5-14.5 V when running on circuit. If you see it running below this, it's likely you have some sort of issue with the charging of your car. After each run it is important to check the data on all areas with "vbat" being included; you'll notice the charging voltage in this section. Follow the below guide on how to diagnose the problem and deciding on the solution.

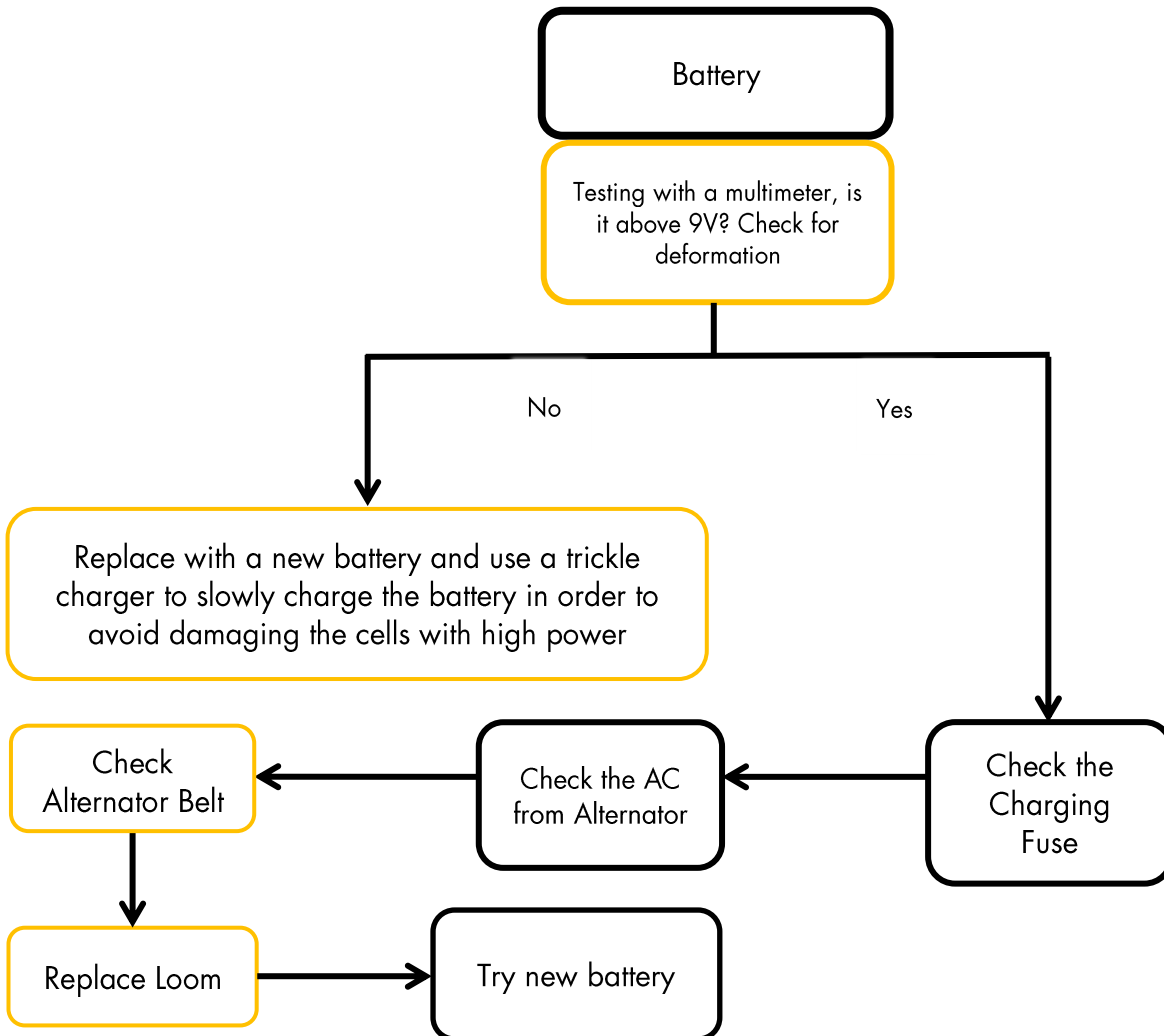

8.3 GEARSHIFT ISSUES

When first discovering a gear shifting issue, it is important to first follow a few steps before attempting any remedy for the issue.

1. First of all, plug into the car and using the 'Data Analysis Manual' as a reference and download the data. Once the data has been downloaded, review the 'GearShiftDecision' channel to see if any shifts have been disallowed due to a breach in the cars normal parameters, TPS Too High/RPM Too High etc. The shift will not be allowed if it sees any of these, and 'GearShiftDecision' will tell you if there have been any dis-allowed shifts.
2. Next step is to open up LifeMon and check whether there is any output from the paddles. Do this by viewing the 'PaddleSwitch' channel, this will give a live reading of the paddle inputs, check the switches are registering on this channel by displaying up/down. If there is no output, check the wire from the steering wheel is still plugged in and has no breaks or tight bends.
3. Is it shifting through all gears? Or just having trouble with one specific gear? If one specific gear this suggests it may be a mechanical issue and it is strongly advised to contact Radical HQ using the given contact details for more advice on what to do. If you have carried out the first two steps and are still having issues shifting through all gears, take a look below for more help, or contact the factory.

DOWNSHIFT ISSUES

Ensure the blip is between 20-35% also check it is blipping mechanically at the actuator end. Check actuator bearings for play, check actuator length using the jig, check the TPS is set at 4% at rest and operating normally, check 'GearShiftDecision' for any dis-allowed shifts.

ISSUES GETTING OUT OF NEUTRAL

Come off of the clutch then press the clutch down again and try to shift. Check actuator bearings for play, check actuator length using the jig, check the TPS is set at 4% at rest and operating normally, check the clutch switch is sending a signal, check the clutch clearance is correct at the pedal.

UPSHIFT ISSUES

Check actuator bearings for play, check actuator length using the jig, check the TPS is set at 4% at rest and operating normally, check 'GearShiftDecision' for any dis-allowed shifts.

8.4 RELAYS

The fuel pump, fan and water pump relays are all housed behind the ECU panel. The compressor relay is on the right hand side of the engine bay tied to the chassis rail.

9. TORQUE FIGURES AND DIAGRAMS

9.1 ENGINE AND GEARBOX

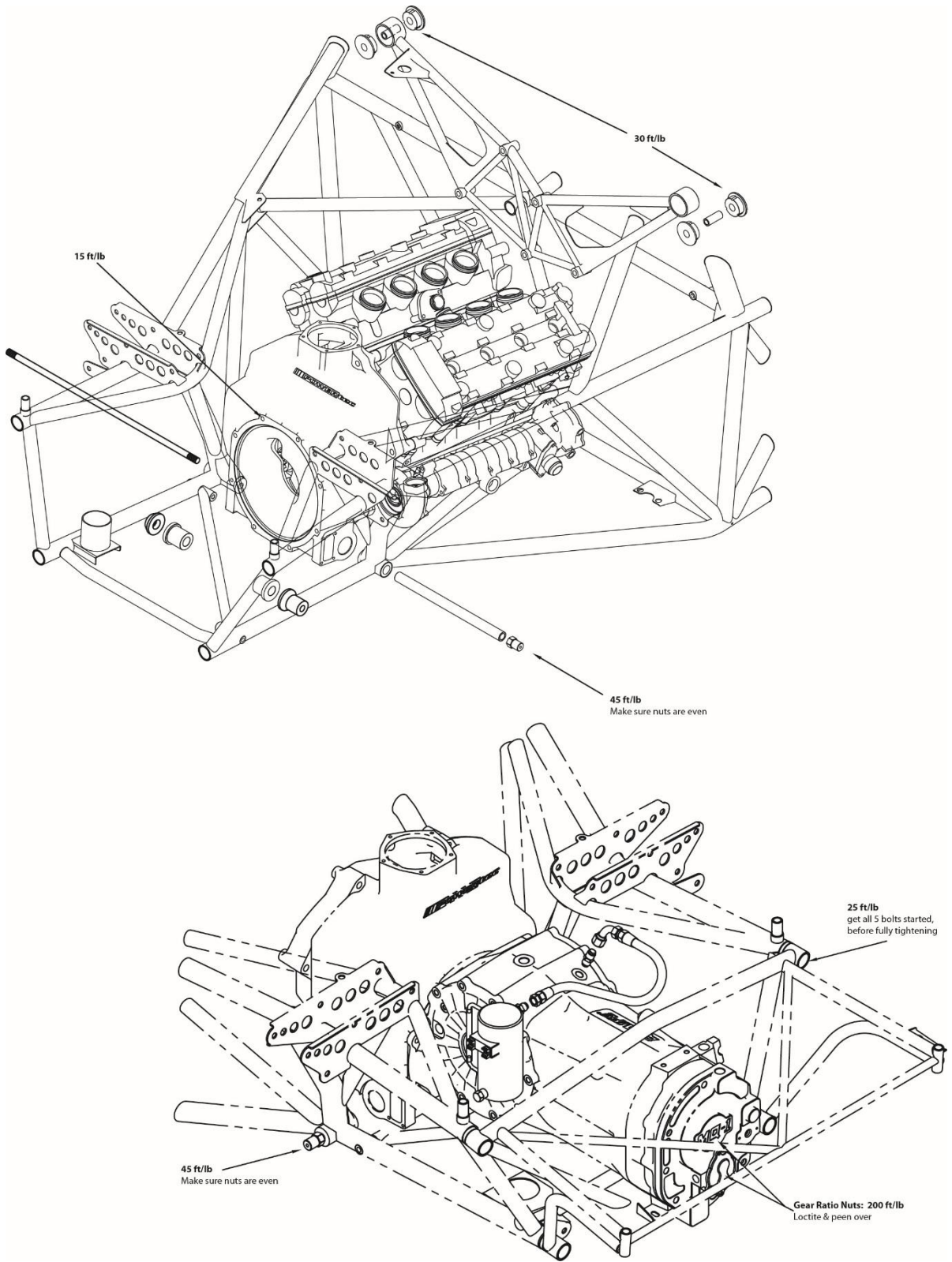

9.2 SUSPENSION COMPONENTS

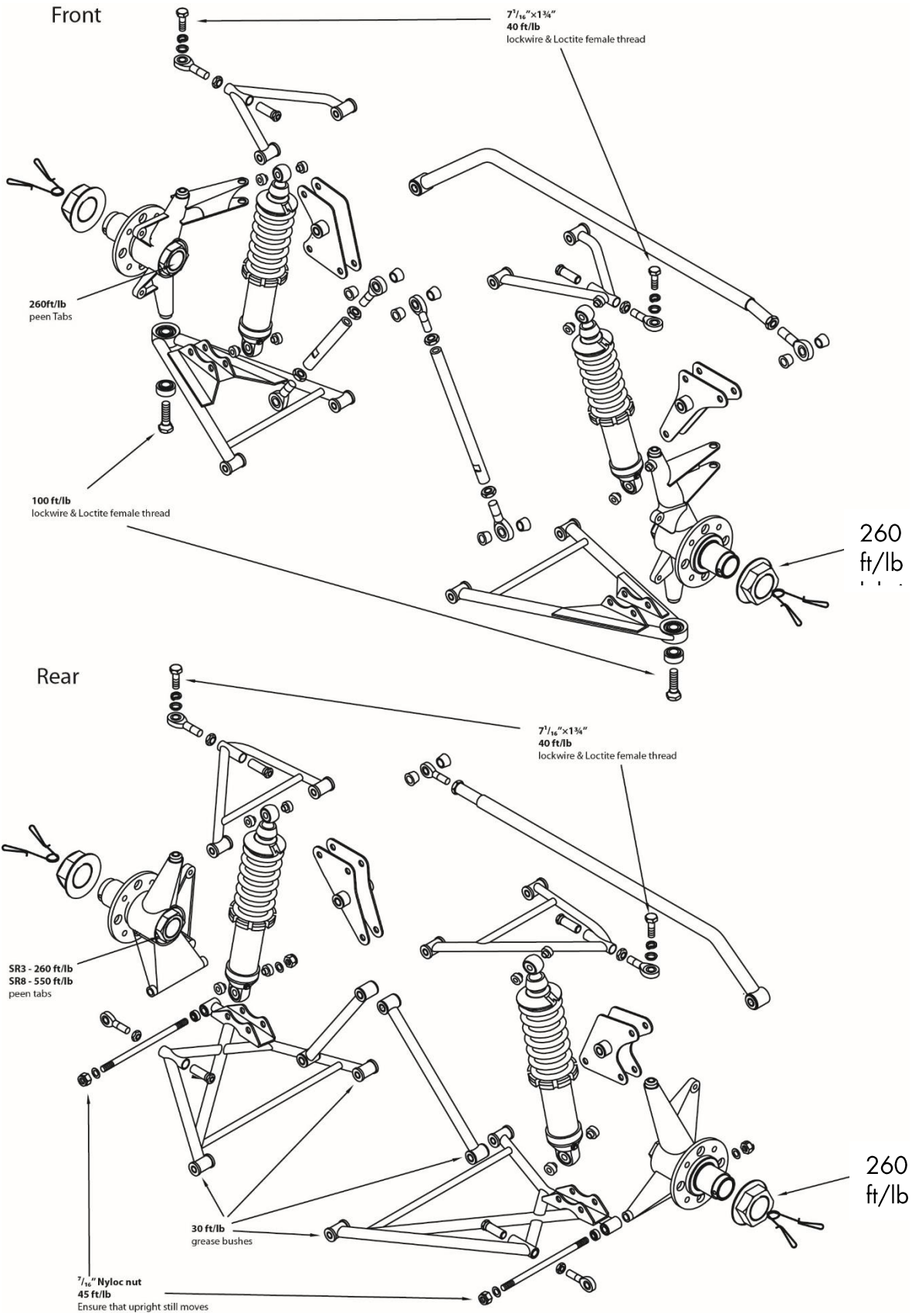

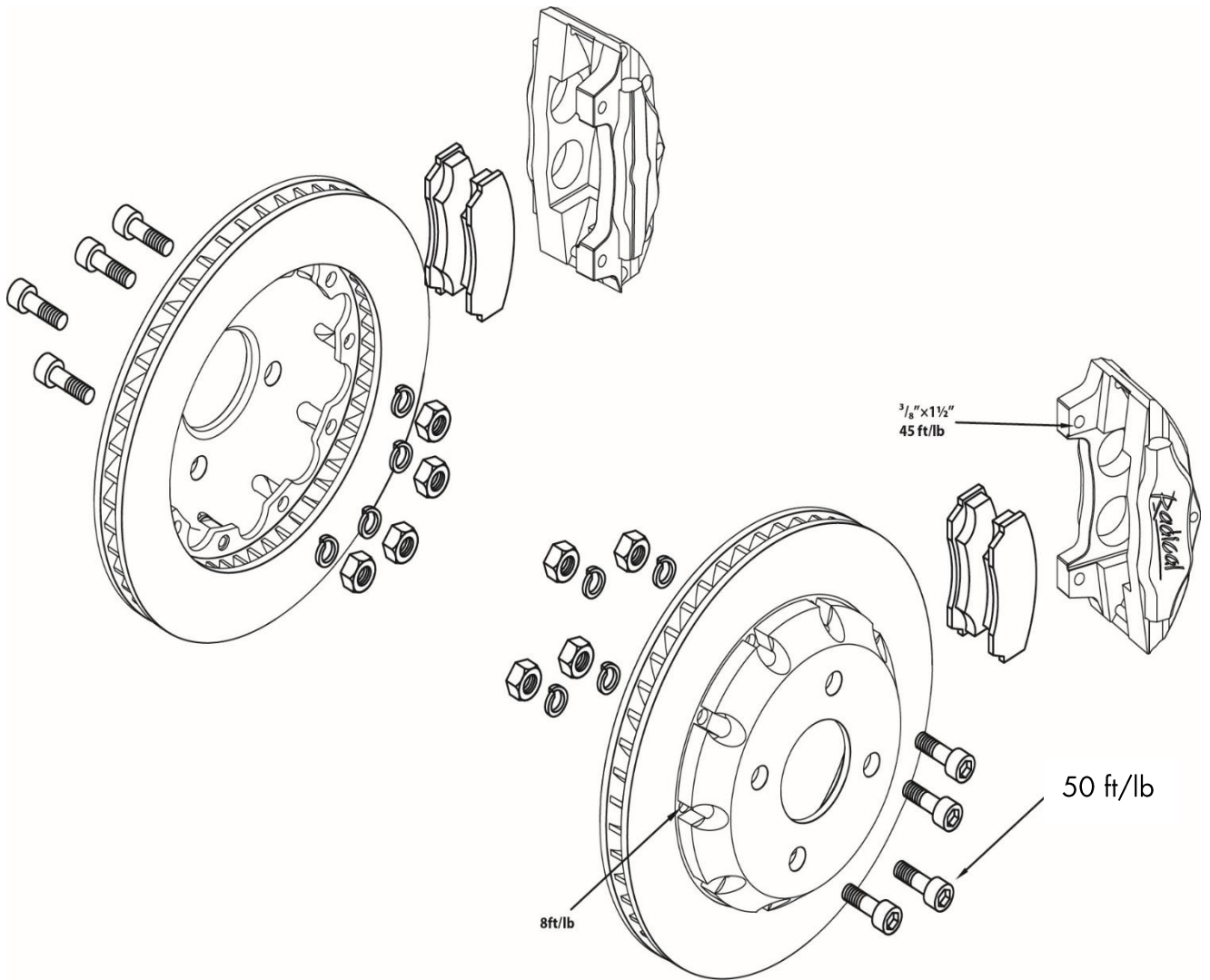

DRIVE SYSTEMS

To be used as a guide only, nuts and bolts should be checked often and tightened as necessary.

E-58G/72G SR8:		
QTEC End Nut/Bolt	648 Loctite/Peened	200 Ft/Lbs
Crownwheel Bolts	648 Loctite/Lockwire	90 Ft/Lbs

SUSPENSION

Wheel Bearing/Hub		
Front SR8	Nyloc	180 Ft/Lbs
Rear All Models	Peened	180 Ft/Lbs
Wheel Nuts		
Centre Lock Nuts	Retaining Clip	260 Ft/Lbs
Uprights		
Front/Rear Upper Bolts	243 Loctite/Lockwire	40 Ft/Lbs
Front Lower Bolt	243 Loctite/Lockwire	100 Ft/Lbs
Braking System		
Floating Disc To Bells	Lockwire	6 Ft/Lbs
Brake Disc To Hub Bolts	Spring Washer	80 Ft/Lbs
Caliper Bolts	Schnorr Washer	48 Ft/Lbs

ENGINE

Engine (RPE)		
(V8) Flywheel	Apply Engine Oil To Thread	5 + 45° Ft/Lbs
(V8) Clutch Housing Nuts	K-Nuts	23 Ft/Lbs
(V8) Alternator Bracket Bolts	-	34 Ft/Lbs
(V8) Spark Plugs	-	8 Ft/Lbs

Advisory generalised bolt torques:

Bolt size/Thread pitch	Grade 2	Grade 5	Grade 8
1/4-20	6	10	12
1/4-28	7	12	15
5/16-18	13	20	24
5/16-24	14	22	27
3/8-16	23	36	44
3/8-24	26	40	48
7/16-14	37	52	63
7/16-20	41	57	70
1/2-13	57	80	98
1/2-20	64	90	110
9/16-12	82	120	145
9/16-18	91	135	165
5/8-11	111	165	210
5/8-18	128	200	245
3/4-10	200	285	335
3/4-16	223	315	370

Bolt size (mm)	Low Grade	Grade 8.8	Grade 10.9	Grade 12.9
6	3-5	7	10	12
8	8-12	17	24	29
10	15-22	33	47	57
12	39	59	83	100
14	60	101	131	158
16	60-94	146	202	247
18	60-130	201	283	340
20	166-188	285	401	482

*All settings above are listed in Ft/Lb.

9.4 ENGINE CONTROL PARAMETERS

Feature	Parameter
Coolant Fan On	92°C
Coolant Fan Off	88°C
High Coolant Temperature Trip	120°C
Low Fuel Pressure Trip	2.2bar
Low Oil Pressure Trip	50psi @ 10,000rpm (RPM Dependant)
Rev Limit	10,500rpm

9.5 COMMON PARTS

Part	Description	Part Number
Brake Disc L/R	300mm Sided	BD0066/67
Brake Bell	-	BD0065
Brake Bobbins	-	BD0061
Front Master Cylinder	7/10	BM0092
Rear Master Cylinder	3/4	BM0093
Clutch Master Cylinder	5/8	BM0091
Dzus Clips	-	MF0182
Wheel Speed Sensor	2mm airgap	LS0080
Oil Pressure Sensor	-	LS0076
Water Temp Sensor	-	LS0028
Spark Plugs	Without Caps	LP0011
Injectors	Ford Injectors	FB0060
Air Temp Sensor	-	LS0093
Mirror Glass	-	AM0022
Side Skirt	-	MA0006/G3
Paddle Set	-	TP0111
Fuel Pump	-	FP0030
Valve Block	-	TP0138
Driveshaft	-	TQ0080
Water Pump	-	HP0014
Paddle Shift Relay	-	LS0072
Relay	Fuel Pump/Fan	LS0016
Brake Pads	F/R	BD0011
Paddle Shift Loom	-	LH0176
Compressor Motor	-	TK0004
BAP Sensor	-	LS0082
Fuel Regulator	-	FR0017
Fuel Filter	-	FF0005
Coil Pack	-	LE0020

9.6 FLUIDS

Below is a list of all the fluids that you will need to run your SR8, including part numbers and quantities required:

Type	Part Number	Capacity	Brand	Viscosity/Type	Required
Engine Oil	EO0048	12L	Motul 300V	15W/50	9L
Brake/Clutch Fluid	BF0006	0.5L	Castrol	SRF	1L
Gearbox Oil	TO0010	1L	Neo Synthetics	75W/90	3.7L (Dry)
Coolant	HW0001	1L	Triple QX	50:50 Mix	10.5L
Aluminium Paste	AC0040	Can	Tygris	Aerosol	N/A

9.7 ROLL BAR SIZES

Front				
Soft	5/8"	15.8mm	Gold	SN0006
Medium	3/4"	19.0mm	Gold	SN0005
Hard	7/8"	22.2mm	Gold	SN0004
Extra Hard	7/8"	22.2mm	Black	SN0071

Rear				
Soft	1/2"	12.7mm	Gold	SN0018
Medium	5/8"	15.8mm	Gold	SN0017
Hard	3/4"	19.0mm	Gold	SN0016
Extra Hard	7/8"	22.1mm	Gold	SN0066
XX Hard	7/8"	22.1mm	Black	SN0073

9.8 GEAR RATIOS

@10,000rpm	SHORT	MEDIUM	LONG	X LONG
Gear	Speed in KPH			
1st	109	109	109	109
2nd	149	149	149	149
3rd	170	178	178	178
4th	192	206	206	206
5th	214	229	237	237
6th	235	257	272	279

SHORT RATIO SET			
Gear	Ratio	Part No	Notes
1 st	12:34	TQ0300+299	Same on all sets Input Shaft/Gear
2 nd	14:29	TQ0301	Same on all sets
3 rd	16:29	TQ0302	
4 th	18:29	TQ0304	
5 th	18:26	TQ0306	
6 th	19:25	TQ0308	
MEDIUM RATIO SET			
Gear	Ratio	Part No	Notes
3 rd	15:26	TQ0303	Same as 3 rd long & 3 rd extra long
4 th	18:27	TQ0305	Same as 4 th long & 4 th extra long
5 th	20:27	TQ0307	
6 th	20:24	TQ0310	
LONG RATIO SET			
Gear	Ratio	Part No	Notes
3 rd	15:26	TQ0303	Same as 3 rd long & 3 rd extra long
4 th	18:27	TQ0305	Same as 4 th long & 4 th extra long
5 th	20:26	TQ0309	Same as extra long
6 th	22:25	TQ0311	
EXTRA LONG RATIO SET			
Gear	Ratio	Part No	Notes
3 rd	15:26	TQ0303	Same as 3 rd long
4 th	18:27	TQ0305	Same as 4 th long
5 th	20:26	TQ0309	Same as 5 th long
6 th	19:21	TQ0312	

9.9 STANDARD (LONG) GEAR RATIO CHART

Final Drive	8	30	0.2667
Bevel Gear	1	1	1.0000
Transfer gear	1	1	1.0000
Tyre Diam	0.614	Dunlop	
Max RPM	10500		

Gear	Input	Output	Ratio	Speed Mph	Speed Kph	Rev Drop
1st	12	34	0.3529	68	109	7311
2nd	14	29	0.4828	93	149	8368
3rd	15	26	0.5769	111	178	8654
4th	18	27	0.6667	129	206	8667
5th	20	26	0.7692	148	237	8741
6th	22	25	0.8800	170	272	-

Item #	Radical Part #	Supplier Part #	Description	Qty
1	TQ0316	E58G103	Bearing Plate	1
2		E58G105	End Cover	1
3	TQ0164	E58G140	1st Gear - Input (R.2600:1)	1
4		E58G141	2nd Gear - Input	1
5	TQ0159	E58G142	3rd Gear - Input	1
6	TQ0160	E58G143	4th Gear - Input	1
7	TQ0163	E58G144	5th Gear - Input	1
8	TQ0161	E58G145	6th Gear - Input	1
9	TQ0164	E58G246	1st Gear - Output	1
10		E58G247	2nd Gear - Output	1
11	TQ0159	E58G248	3rd Gear - Output	1
12	TQ0160	E58G249	4th Gear - Output	1
13	TQ0163	E58G250	5th Gear - Output	1
14	TQ0161	E58G251	6th Gear - Output	1
15	TQ0186	E58G252	Reverse Gear - Output	1
16	TQ0199	E58G153	Reverse Gear - Input	1
17	TQ0223	E58G181	Pinion - Spiral Bevel (R.4111:1)	1
18	TQ0325	E58G3102	Inner Track (Splined Hub)	2
19	TQ0162	E58G2103	Drive Disc (Dog-ring)	4
20	TQ0323	E58G1104	Thrust Washer	2
21	TQ0193	E58G2106	Inner Track (Reverse Gear)	1
22	TQ0352	E58G1107	Spacer - Input Shaft	3
23	TQ0168	E58G2108	Selector Fork - 5th/6th	1
24	TQ0274	E58G2110	Camdrum Spindle	1
25		E58G2112	Reverse Track (Normal Rotation)	1
26		E58G2112A	Reverse Track	1
27	TQ0170	E58G1113	Selector Fork Support Rod	1
28	TQ0191	E58G2115	Reverse Fork Pin	1
29	TQ0192	E58G2116	Selector Fork - Reverse	1
30	TQ0270	E58G1119	Camdrum (6 Speed Reverse Rotation)	1
31	TQ0249	E58G1126	Index Screw	1
32	TQ0240	E58G1128	Ratchet Claw Stop	2
33	TQ0215	E58G1129	Selector Fork - 3rd/4th	1
34	TQ0317	E58G1130	Inner Track (Splined Hub)	1
35		E58G1EX02	Flare Cap - (5929-06)	2
36	n/a	n/a	n/a	n/a
37	TQ0132	E6G169	Hollow Dowel (M10)	3
38	TQ0341	E15G121	Thrust Washer - Reverse Idler	1
39		E18G164	Housing - Guide Tube	1
40		E18G165	Guide Tube	1
41		E18G466	Slider/Piston	1
42		E18G1176	Fulcrum Ring	1
43		E25G1181	Clutch Unit Spacer	1
44		E32G1118	Washer	2
45	TQ0241	E33G173	Interlock Housing Cap	1
46	TQ0272	E34G144	Sensor Drive Plug	1
47	TQ0268	E34G1112	Thrust Washer - Reverse Gear O/P Shaft	1
48	n/a	n/a	n/a	n/a
49		E42G203	Main Casing	1
50		E42G1093	Crown Wheel - Spril Bevel R4.111:1	1
51	TQ0351	E42G1108	Bearing Retainer Cap	2
52	TQ0214	E42G2111	Selector Fork - 1st/2nd & 3rd/4th	1
53		E42G1115	Drum Bush Flange	1
54	TQ0271	E42G1119	Drum Bevel Gear	1
55	TQ0236	E42G1121	Spool Geal Spindle	1

Item #	Radical Part #	Supplier Part #	Description	Qty
56	TQ0198	E42G2122	Reverse Idler Spindle	1
57	TQ0366	E42G2123	Bush - Gear Change Spindle	1
58	TQ0230	E42G1124	Operating Spindle	1
59		E42G2128	Crownwheel Bearing Retainer Plate	1
60	TQ0227	E42G1183	Cable Operating Arm	1
61	TQ0383	E42G1132	Oil Pump Cover	1
62	TQ0217	E42G1135	Shaft Clamp Screw	1
63	TQ0237	E42G1139	Interlock Plunger Neutral	1
64	TQ0220	E42G2140	Pump Gear Drive	1
65	TQ0355	E42G1152	Threaded Dowel	2
66	TQ0282	E42G1151	End Case Bung	1
67	TQ0371	E42G1153	Pinion Spacer	1
68	TQ0228	E42G1154	Nut - Output Shaft	1
69		E42G1162	Cover - Diff Retainer	1
70	TQ0208	E42G1165	Ball Bearing	1
71		E42G1167	Cover - Diff Retainer	1
72	TQ0298	E42G1179	Input Shaft	1
73		E42G1187	Flange Retaining Bolt	2
74	TQ0234	E42G1203	Bevel Gear Spool	1
75	TQ0239	E42G1213	Clamp Plate Return Spring	1
76	TQ0251	E42G1214	Ratchet Arm Lever	1
77	TQ0235	E42G1215	Ratchet Pin	2
78	TQ0224	E42G1216	Ratchet Claw	1
79	TQ0233	E42G1218	Gear Change Cover	1
80	TQ0197	E43G1017	Reverse Idler Gear	1
81		E52G155	Thrust Washer 1st Gear Output	1
82	TQ0324	A3R142	Oil Pump Gear (Driven)	1
83	n/a	n/a	n/a	n/a
84	TQ0242	F5F107	Hollow Dowel	2
85		QDF2Q	Differential	1
86	TQ0356	209	Bolt	11
87	TQ0134	225	Ball Bearing	2
88	TQ0171	317	Circlip 18mm	1
89		389	Bolt	2
90		442	Bolt	3
91	TQ0026	450	Roller Bearing	1
92	TQ0246	455	Circlip	2
93		471	Bolt	1
94	TQ0219	475	Gearbox Oil Seal	2
95		480	Bolt	1
96		507	Bolt	5
97	TQ0255	519	Bolt	7
98	TQ0218	584	Gearbox Oil Seal	1
99		595	Sellock Pin	1
100		609	O-Ring Seal	1
101		684	Bolt	10
102		758	Nut - Nyloc M6	2
103		775	Bolt	2
104	TQ0295	797	Bush	2
105		801	Bolt	2
106		817	Washer	1
107	TQ0245	831	Dowel	12
108	TQ0221	838	Roller Bearing	1
109	TQ0201	842	Roller Bearing	1
110	TQ0229	870	Taper Roller Bearing	2

Item #	Radical Part #	Supplier Part #	Description	Qty
111	TQ0143	879	Schnorr Washer M6	22
112	TQ0144	880	Schnorr Washer M8	30
113		881	Schnorr Washer M10	15
114	TQ0283	883	Magnet End Case Bung	1
115	TQ0202	939	Dowel	1
116		971	Nut - Nyloc M8	1
117		988	Bolt	1
118	TQ0200	1003	Gearbox Bearing	1
119	TQ0294	1013	Bearing	1
120		1022	Circlip - Internal	1
121	TQ0039	1035	Gearbox Oil Breather	1
122		1070	Washer	2
123	TQ0287	1071	Oil Seal	1
124		1109	Schnorr Washer M4	7
125	TQ0247	1124	Washer	2
126	TQ0205	1156	Roller Bearing	7
127	n/a	n/a	n/a	n/a
128	TQ0203	1240	Circlip	1
129		1261	Washer	1
130	TQ0344	1271	Bush	3
131	TQ0296	1295	Bush	2
132	TQ0273	1296	Dowel	1
133	TQ0361	1297	Bush	1
134		1310	Bearing	1
135	TQ0243	1389	Bolt	2
136	TQ0244	1399	Bolt	1
137	TQ0348	1441	Dowty Seal	1
138	TQ0209	1451	Roller Bearing	1
139	TQ0276	1454	Plug	2
140	TQ0326	1460	Stud	20
141	TQ0248	1463	Stud	6
142	TQ0211	1465	Stud	7
143		1466	Nut - Kaylock M10	7
144		1467	Nut - Kaylock M8	20
145		1468	Nut - Kaylock M6	6
146		1469	Washer	2
147		1488	O-Ring	1
148		1489	O-Ring	1
149		1490	O-Ring	1
150		1584	Hose Union	2
151				
152				
153				
154				
155				
156				
157				
158				
159				
160				
161				
162				
163				
164				
165	TQ0225	1641	Ratchet Spring	1
166	TQ0194	1732	Circlip External	1

9.10 EXPLODED DIAGRAM (GEARBOX)

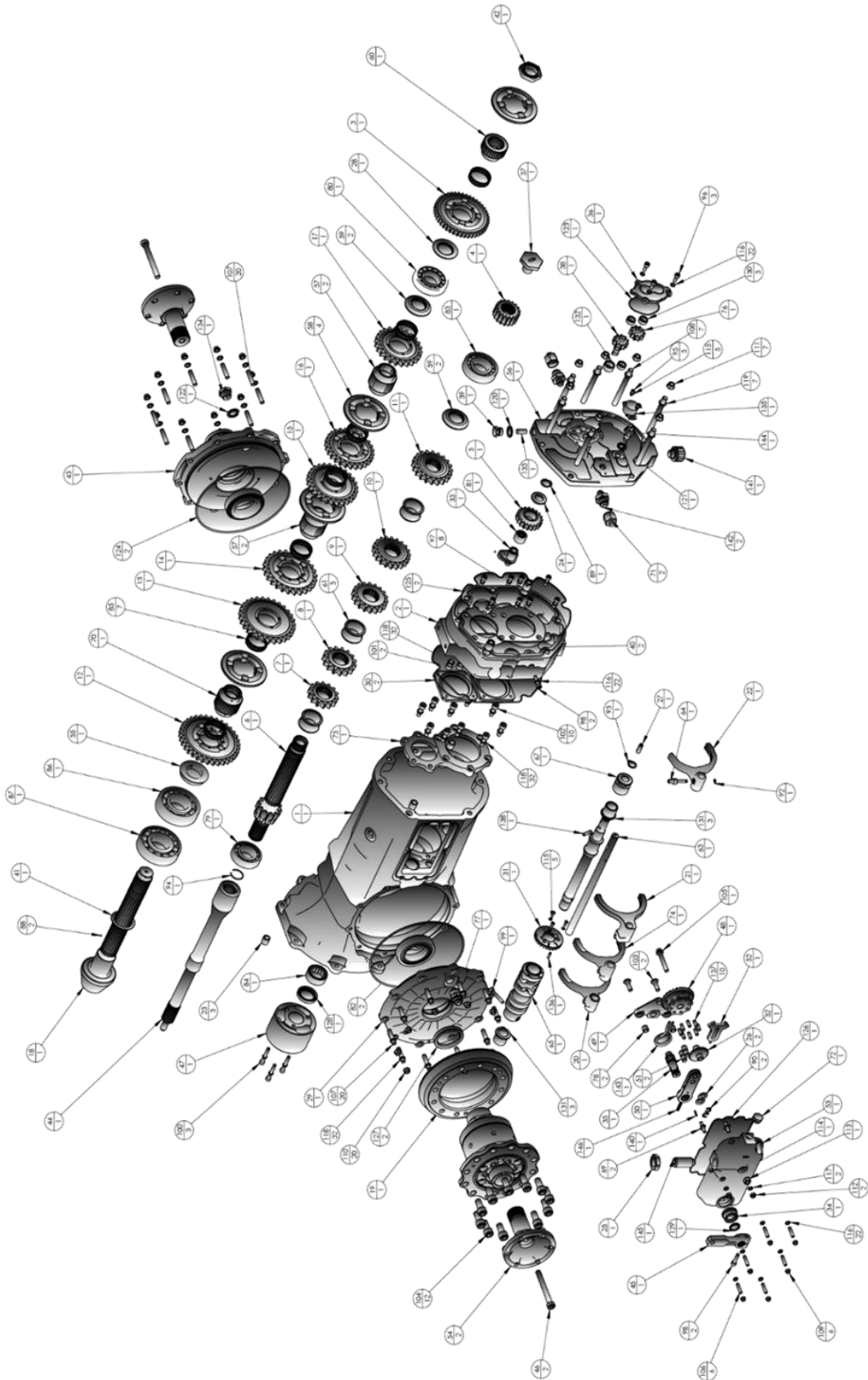

9.11 COMPONENT LIFING

As the performance of our cars increases and the number of hours we log racing the cars grows, we are able to more accurately predict the lifespan of a car's components. Please see below the 'Radical Component Lifespan Chart'.

The chart gives the recommended life expectancy of components under 'normal, on-track racing conditions'. If some of your racing time is done 'off-track' or you hit kerbs, pot holes or other cars, then you will need to reduce the timescales recommended and immediately replace damaged parts.

The recommended life expectancies in no way represent a parts warranty, due to the unpredictable and uncontrolled use of these racing car components Radical will not be held responsible or accountable for any parts failure. This information is provided solely as a guide to increase the safety of the cars.

Component	Action	Interval	
		Hours	Distance (km)
Engine (warranty)	Rebuild	40	N/A
Gearbox rebuild	Inspect/ rebuild	-	4000
Injectors	Service	40	-
Spark plugs	Replace	40	-
Valve block	Check/ tighten	-	4000
Calipers	Rebuild	-	4000
Shock absorbers	Dyno check	-	4000
Driveshafts (complete)	Replace	-	8000
Suspension bushes	Replace	-	2000
Suspension rose joints	Replace	-	6000
Front Uprights inc. Hubs	Replace	-	6000
Rear Uprights inc. Hubs	Replace	-	6000
Wishbones	Inspect/ replace	-	8000
Master cylinders	Replace	-	8000
Battery	Replace	Annually	-
Fuel tank	Inspect	Annually	-
Steering rack	Rebuild	Annually	-

9.12 SERVICE SCHEDULE

The below intervals are intended as a guide to assist in components achieving full life and reliability of your engine and gearbox. These intervals are based on Radicals recommended oils which can be found in the fluid specifications section of this manual.

Component	Action	Interval track (hours)
Engine oil	Replace	6
Engine oil filter	Replace	6
Gearbox oil	Replace	6
Engine air filter	Replace	40
Fuel filter	Replace	40
Gearbox inspection	Inspect / replace	6
Paddleshift actuator bearing	Inspect / replace	10

9.13 GEARBOX INSPECTION PROCEDURE

This must be carried out on a hard, level workshop floor.

Tools required – 42mm socket (45mm socket is also required for 2012 onwards cars)

Allen key set

External circlip pliers

Socket set

Medium size puller

½ drive impact gun

14mm open-ended spanner

Please note: on the tag number of the gearbox, the 'H' prefix denotes hypoid type gearbox.

ONLY AN EXPERIENCED TECHNICIAN SHOULD CARRY THIS OUT.

9.14 REMOVAL AND DISASSEMBLY

1. Remove two bolts at the rear and two from the sides of the rear diffuser. Slide out rear diffuser from under the car.
2. Jack up car using the rear jacking point and place jack stands underneath the chassis rail to support the car.
3. Remove rear wheels and bodywork.
4. Remove rear silencer/s and rear tail mounting frame. Place an oil tray under the rear of the gearbox and disconnect all wires and oil hoses from the rear of the gearbox.
5. Remove the compressor-mounting tube. (Four bolts and nuts)
6. Remove the two 8mm bolts and spacers from the ends of the outer driveshaft joints (refer picture 1)
7. Remove inner driveshaft boot retaining clips and pull the boot off the inner joint
8. Remove the rear upright upper bolt.
9. Remove the driveshaft joint from the upright and slide out of the inner joint.
10. Inside the inner joint will be a rubber plug. Remove the plug and inside will be an 8mm cap head bolt. These need to be removed also. Pull the inner joint out of the gearbox
11. Remove oil cooler return line.
12. It is strongly recommended that the gearbox be removed from the car so as the clutch release system can be inspected also. To do this you need to disconnect the clutch lines, reverse lock-out cable (IF FITTED), gear selector (rod or plugs on the actuator) and remove the k nuts from around the front of the gearbox and one 6mm cap head bolt
13. The gearbox can then be lifted out of the car. Place gearbox on suitable bench and stand.
14. Remove all the nuts around the rear gold coloured cover, and remove it, taking care not to damage the o-ring seal in behind the cover.
15. You will need a 42mm socket and impact gun to remove the large bolt and nut from the end of the shafts. (45mm socket is required on the large pinion nut on 2012 onwards cars)
16. Ensure the gearbox is in neutral and mark the position of the reverse selector barrel on the end of the shaft and on the barrel itself. (Refer picture 2) this will aid in correct fitment when re-assembling.
17. Remove the circlip from the selector barrel
18. On the outside of the gearbox is a 6mm caphead bolt (refer picture 3) removing this bolt also. It is not necessary to remove the selector cover to inspect the gears
19. Before removing the gears from the two shafts, ensure you have a clean area set aside to lay the gears out as you remove them or use a gear stand to keep them in order.
20. Slide the reverse gear assembly and selector fork and shaft off the pinion shaft.
21. Remove the reverse selector barrel-locating pin.

22. Remove the circlip from the reverse gear idler. There is a washer in behind this gear that is located with a very small ball bearing. Use caution when removing, as it can be lost very easily. Inspect the gear and bearings for wear or damage.
23. Remove the reverse gear from the lay shaft.
24. In behind the gears are a cone spacer and the bearing races. There is also two cone spacers on the other side of the centre bearing housing that looks similar but is a different thickness. Pay close attention to the location of these.
25. Remove the two threaded dowels locating the centre bearing housing.
26. Using a soft face hammer, tap the housing towards the rear of the gearbox to remove it from the studs.
27. Inspect the bearings and o-ring seals on the centre support housing and clean ready for reassembly
28. It is sometimes required to use a bearing puller to remove the pinion shaft support bearing inner race. (and cone spacer)
29. Remove the gears and selector forks noting their location and gear pairing as you do this. It is wise to mark the pairs of gears and the selector forks if you feel you may get them mixed up.
30. At the pinion end of the pinion shaft is a spacer that has a very small ball bearing used for locating the spacer. Remove the spacer and remove the ball bearing, as it is very easy for this ball bearing to get lost or damaged.
31. Inspect the 'dogs' on all the gears and clutch rings for damage.
32. Inspect all the gears for wear or damage
33. Inspect the clutch forks for wear on the selector barrel pins and for wear or damage to the fork itself.
34. Inspect all bearings and races for wear or damage
35. Remove the 1st gear lay shaft / input shaft assembly. Inspect for damage or wear.
36. Pay close attention when inspecting all of the internals of the gearbox. Anything missed during the inspection can lead to shift problems or gearbox failure. Replace anything that is suspect!
37. Next the nuts holding on the differential side cover. (Bright machined aluminium one). Remove the side cover carefully so as not to damage the o-ring seal around the cover.
38. Lift out the differential assembly.
39. Inspect the crown wheel and pinion gear for signs of wear.
40. Inspect the differential assembly for cracks or damage. Ensure the lock wire is in place correctly that holds the crown wheel bolts secure.
41. Inspect the input shaft bearing and the differential side bearings.
42. Clean all parts, inspecting them as you do so. Clean out main gearbox casing and check for crack or damage.
43. Using a torch. Inspect the selector barrel for wear or damage. Inspect the tracks and ensure a smooth operation of the selector barrel

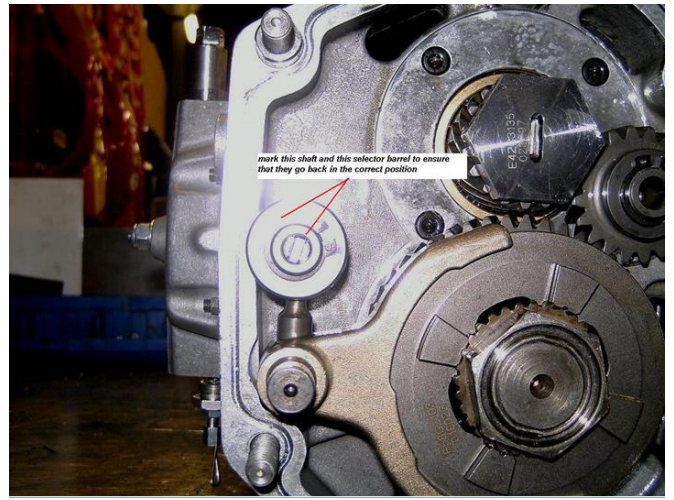

When re-assembling the gearbox, use gear assembly lube or thicker type oil to ensure that the oil remains on the internals during re-assembly. Liberally coat all bearings and gears during re-assembly.

1. Carefully refit the 1st gear / input shaft assembly into the housing.
2. Refit the crown wheel / differential assembly. Inspect the side cover o-ring for any damage and use a light sealant such as hylamar or similar and lightly coat the o-ring. Re-fit the side cover and retaining nuts and washers.
3. Refit small ball bearing into the pinion shaft and re-fit the front cone spacer
4. Re-fit the gears, spacers, bearings and selector forks in the order in which they were removed, ensuring that the selector fork barrel pins are correctly located into the barrel tracks.
5. Re-fit the two cone spacers in the correct position and the centre support bearing inner races.
6. Coat the centre housing inner o-ring with hylamar or similar light sealant. Ensuring that the o-ring is located properly.
7. Slide the centre housing onto the studs and re-fit the lay shaft bearing inner race as you slide it on and locate. Re-fit threaded dowels.
8. Re-fit the pinion shaft cone spacer.
9. Re-fit reverse gear onto the lay shaft
10. Re-fit the pinion reverse gear
11. Re-fit the reverse idler gear assembly, ensuring that the small locating ball bearing has been fitted to locate the washer. Refit the circlip.
12. Re-fit the reverse selector barrel-locating pin into the shaft.
13. Re-fit the reverse selector fork / selector shaft assembly, sliding it on with the reverse clutch ring and selector barrel. Ensure that the barrel lines up with the marks you made before disassembly.
14. Re-fit the selector barrel circlip
15. Add some high strength loctite to the treads of the lay shaft-retaining nut and to the pinion-retaining bolt. Tighten up using 42mm socket and impact gun.
16. Re-fit the 6mm cap head selector shaft locating bolt into the side of the housing.
17. Re-fit rear o-ring coating it with hylamar and ensure that it is located in the housing correctly.
18. It is best to remove the gear position sensor from the housing before re-fitting the cover as if it is lined up incorrectly, it can become damaged.
19. Ensure the oil pump drive is lined up correctly and re-fit the rear cover, nuts and washers.
20. The gear position sensor needs to re-fitted when the gearbox is in the car, as you will need it connected to the dash display to ensure correct position.
21. Manually change gears and rotate the input shaft to ensure that you can select all the gears, including reverse and that there are no tight spots or lock ups. **This is vital to ensure that you have assembled the gearbox correctly**
22. Inspect the clutch release assembly before re-fitting; making sure that the bearing, piston and seals are in good condition. Ensure the clutch lines are not damaged and are tight.
23. Re-fit to the car, making sure you don't damage the clutch line when positioning the gearbox into the bell housing.
24. Tighten the k nuts and 6 mm bolt.
25. Re-fit oil cooler return line
26. Clean the inner driveshaft pots and re-fit into the gearbox taking care not to damage the seals.
27. Put some Loctite on the threads of the inner pot retaining bolts and tighten. Re-fit inner pot rubbers.
28. Put some fresh grease into the inner pot
29. Clean and inspect the inner driveshaft joint bearings.
30. Slide the joint into the inner pot and position outer joint into the rear upright. Put some Loctite onto the upright bolt and re-fit.

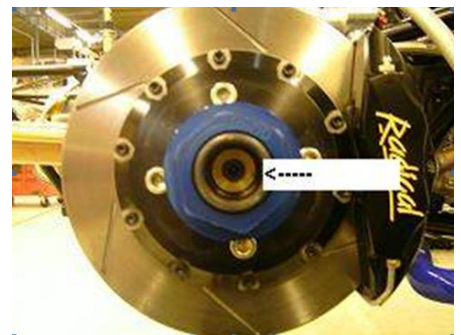

31. Fit inner boots and clips
32. Re-fit out joint locating bolts and spacers in uprights
33. Re-fit compressor mounting tube and re-connect
34. Re-fit reverse lockout cable
35. Re-connect gear selector (rod or actuator plugs)
36. Connect gear position sensor. Make sure the gearbox is in neutral and align the sensor so the dash display reads neutral and re-fit to gearbox ensuring that it locates easily. If force is required it is not lined up.
37. Clean out in-line oil filter and refit oil lines and rear tail mounting frame.
38. If you are repairing a failure or extensive damage to the gearbox, then it is recommended that the gearbox oil cooler be replaced or sonic cleaned
39. Fill gearbox with correct amount and type of oil. (3.7 litres if cooler has been replaced or 3.2 litres if only gearbox has been drained)
40. Check that the gearbox can still select gears correctly using the gear lever or paddles. Have someone turn the rear shafts whilst you select the gears. Ensure that the dash display is reading correctly.
41. Bleed the clutch hydraulic system
42. Make sure that the car is supported well enough, (put jack under jacking point to be sure but leave on jack stands) then warm engine up and run the car up and down the gearbox a few time to ensure correct and smooth operation. Check for any leaks.
43. Re-fit rears wheels and lower onto the ground. Re-fit rear diffuser.

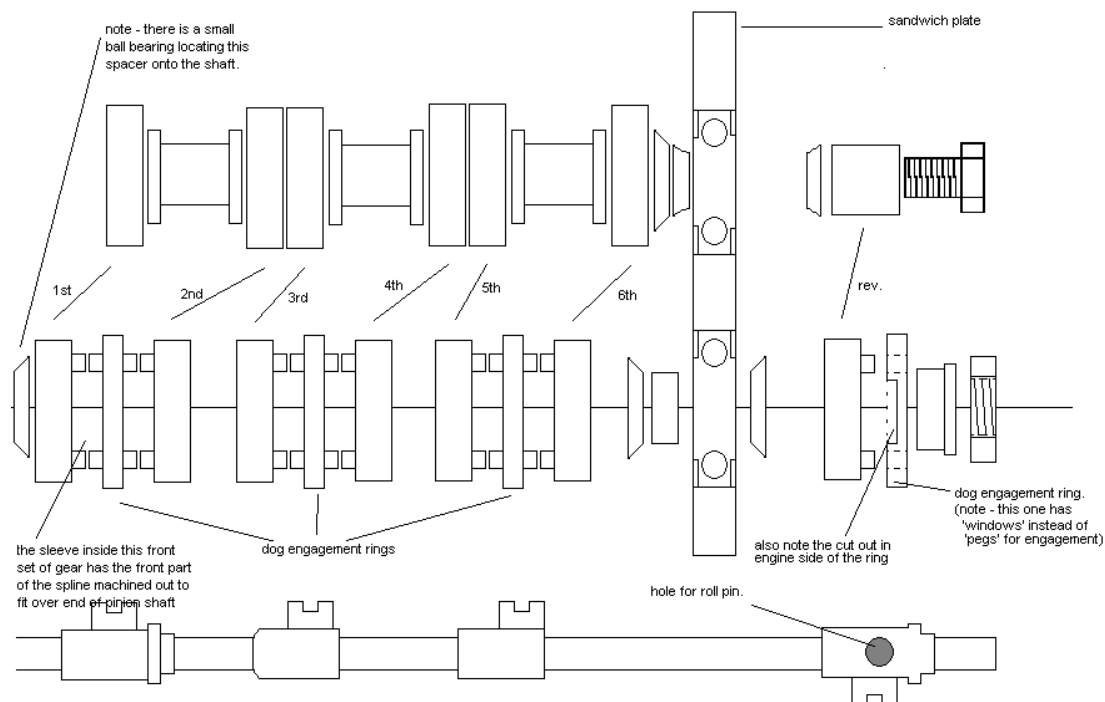

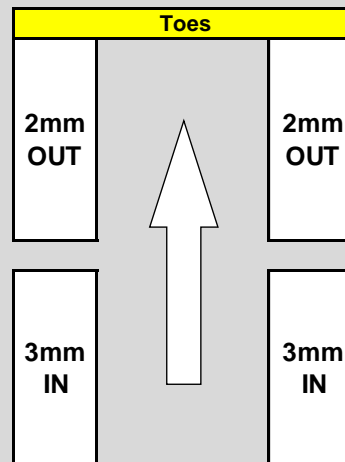
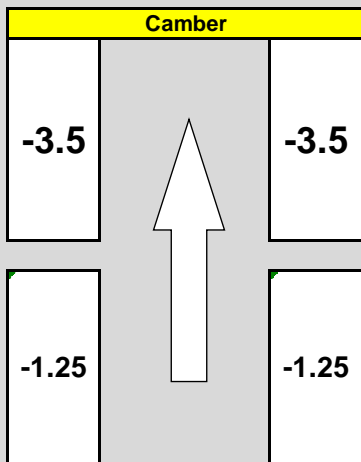

Triple Intrax		Springs/Preload		Triple Intrax		
Bump LS:	-12	95Nm 100mm Preload 3 Turns	FARB	95Nm 100mm Preload 3 Turns	Bump LS:	-12
Bump HS:	-25		Soft 15.8mm		Bump HS:	-25
Rebound:	-25		Medium 19mm		Rebound:	-25
			Hard 22.2mm X Hard 22.2mm black			

Corner weights(Est) / Drop Height		
75m m	Front diffuser H	75mm
	40mm	
168m m	Ballast Weight	168mm
	80kg	
Weight Estimate	Cross%	Weight Estimate
153	50.3	160
	Total weight kg	
	715 +80kg BW*	
	Rake mm	

Triple Intrax		Springs/Preload		Triple Intrax		
Bump LS:	-10	110Nm 100mm Preload 0 Turns	RARB	110Nm 100mm Preload 0 Turns	Bump LS:	-10
Bump HS:	-25		Soft 12.7mm		Bump HS:	-25
Rebound:	-25		Medium 15.8mm		Rebound:	-25
			Hard 19mm X Hard 22.1mm Super hard 22.1 black			

70m m	15mm		70mm
220m m			220mm
Weight Estimate	LHD	RHD	Weight Estimate
222		✓	228

Dive planes:	Tyre Pressures PSI (Cold & Hot)	
	24	24
	Dunlop Tyre Compound	
	720	

PADS
01

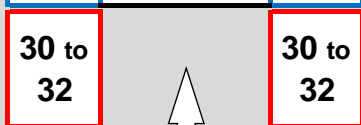

SR8 Gearing	
Short	
Medium	Std
Long	
X long	

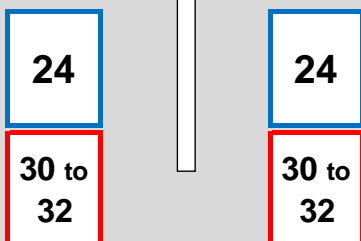
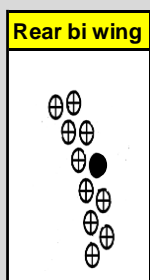

PADS
01

SR3 Gearing	
3.409	n/a
3.235	n/a
3.071	n/a
2.917	n/a

Chain Drive Gearing	
FRONT	REAR
n/a	n/a

Note: When carrying out set-up on flat-patch, set tyre pressures to hot pressure. Ensure that they are returned to cold pressures after setup is complete.

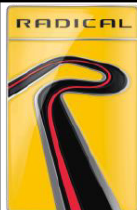

SR8 - Factory setup sheet - Hankook

Note: When carrying out set-up on flat-patch, set tyre pressures to hot pressure. Ensure that they are returned to cold pressures after setup is complete.

Date		Chassis #		Job #	
		Technician	1	Technician	

Camber		
-3.2		-3.2
-1.4		-1.4

Toes		
2mm out		2mm out
3mm IN		3mm IN

Triple Intrax		Springs/Preload			Triple Intrax	
Bump LS:	-10	Rate	FARB	Rate	Bump LS:	-10
Bump HS:	-30	130	Soft 15.8mm	130	Bump HS:	-30
Rebound:	-5		Medium 19mm		Rebound:	-5
		Length	Hard 22.2mm	Length		
		100	X Hard 22.2mm	100		
		Preload		Preload		
		4 turns		4 turns		

Ride	Front Diffuser H	Ride
78mm	40mm	78mm
	Ballast Weight	
	80kg	
Drop	Cross%	Drop
162mm		162mm
Weight	Total weight	Weight
kg	kg	kg

Triple Intrax		Springs/Preload			Triple Intrax	
Bump LS:	-4	Rate	RARB	Rate	Bump LS:	-4
Bump HS:	-20	110	Soft 12.7mm	110	Bump HS:	-20
Rebound:	-30		Medium 15.8mm		Rebound:	-30
		Length	Hard 19 mm	Length		
		100	X Hard 22.2mm	100		
		Preload	XX Hard 22.2mm	Preload		
		0		0		

Ride	Rake mm		Ride
79mm	21mm		79mm
Drop			Drop
209mm			209mm
Weight	LHD	RHD	Weight
kg			kg

Fuel Level

Upper Dive planes:	Y / N
Lower Dive planes:	Y / N

Tyre Pressure (PSI) (Cold & Hot)			PADS
28	Hankook	28	01
20		20	01
28		28	01
19		19	01

Rear Wing	
Holes (from the bottom)	
Main	3 out of 4
Bi-wing	7 out of 9

Comments:

10. VERSION HISTORY

2018-01-10 V1.0 Initial public release

2018-01-29 V1.1 Gearbox oil change added + Motul part numbers. Hankook Setup Sheets and tyre information.

2018-03-20 V1.2 Hankook Update

2018-04-17 V1.3 Hankook Update

2018-06-13 V1.4 Gearbox Update

2018-07-17 V1.5 Pushrod lengths added. Torque units added. Master cylinder part numbers corrected.

